



The S-Class.



Mercedes-Benz



Vision accomplished. The S-Class.

Roll up those sleeves and get stuck into the job to be done – while sitting in the lap of luxury. Roll up the garage doors in the morning ready to work hard – step out onto the red carpet at night ready to play hard. View the rising sun from the driver's seat – and the setting sun from the reclining seat in the rear. The S-Class brings together the worlds of work and leisure at a hitherto undreamed-of level. The choice of materials, the degree of perfection and exclusivity in the interior surpass expectations for a vehicle of this class.

And it is simply in the S-Class's DNA to shine with technical innovations as yet unseen in a car. The ultra-intelligent chassis seems to flatten down the road ahead; the lighting, using new technologies and a 360° sensor system, illuminates the surroundings with a speed and precision never seen before. You will see it, sense it and experience it for yourself: the S-Class shows the way ahead – to the future of autonomous driving.

Overview of the vehicles presented here:

2 | Mercedes-Benz S 500

diamond silver metallic

AMG Line, featuring AMG 14-spoke light-alloy wheels, Exclusive nappa leather upholstery in black/porcelain, designo high-gloss sunburst brown myrtle wood trim

14 | Mercedes-Benz S 300 BlueTEC HYBRID

magnetite black metallic

7-triple-spoke light-alloy wheels, Exclusive package, Exclusive nappa leather upholstery in silk beige/espresso brown, designo high-gloss sunburst brown myrtle wood trim

26 | Mercedes-Benz S 63 AMG

diamond silver metallic

AMG multi-spoke light-alloy wheels, Exclusive nappa leather upholstery in black, AMG carbon-fibre/piano lacquer trim in black

Vision.

40 | Moving innovation

Drive system and chassis.

42 | Diesel and petrol engines

43 | S 300 BlueTEC HYBRID
and S 400 HYBRID

44 | Transmissions

46 | Chassis and suspension

Safety.

48 | Integral safety concept

Comfort.

52 | Assistance systems

54 | Multimedia systems

56 | Seats

57 | Lights and climate control

Model variant.

58 | S 600

AMG.

60 | S 63 AMG

66 | S 65 AMG

68 | AMG Performance Studio

Equipment and appointments.

70 | AMG Line

72 | AMG Line Plus

73 | Exclusive package

74 | Standard equipment

75 | Optional extras

76 | Upholstery and trim

81 | designo

84 | Wheels

85 | AMG wheels

86 | Genuine accessories

88 | Services.

Facts and colours.

90 | Dimensions

90 | Paintwork

91 | Technical data

The first star.
Shining in the morning light too.

The sun lifts the veil of mist from the road, the contours of the S-Class stand out in sharp relief. The upright radiator grille topped by the unmistakable star herald in the new dawn. A new day is breaking – and with it, a new era of mobility.







Prepare to arrive in the future
without covering a single metre of road.



The quickest route
between two points on your agenda.

“The office awaits” – a promise with a pleasant undertone. For even when it comes to the matter of work the S-Class is an oasis. With an air of a purity reminiscent of the coast or forested mountain slopes. Pollutants have to stay outside; ionisation enriches the air in the interior of the luxury saloon. You inhale freedom. Even if you currently find yourself between a handful of skyscrapers and two important appointments.













When can a moment not be surpassed? Or a car? Intense light showcases the immaculate trim. Richly contrasting materials blend to form harmonious surfaces. Exclusive design sparkles with optimum functionality and a predilection for detail. Your glance sweeps through the generous space and your hands rest for a few seconds on the timelessly classic leather of the seats. Before you alight, sure in the knowledge that the perfect day is simply a question of the right vehicle.





Nowadays revolutions are
driven from the executive seat.





Equally at home
with black tie or white collar.





The time is ripe, the way ahead beckons. Truly there could be no more fitting an opportunity in which to meet up with the future. Its 150 kW plus 20 kW (204 hp plus 27 hp) move mountains as if it were an uphill stroll. The S 300 BlueTEC HYBRID offers outstanding ride comfort with low fuel consumption and emissions.







Recharges its batteries while in motion - as you will do, too.

BLUETEC HYBRID





The S-Class will always leave you in control,
never on your own.

The vision of autonomous driving is at your fingertips as you grip the wheel. The S-Class uses its camera and sensor technology to capture your surroundings comprehensively and is fully alert to what it records. An intelligent suspension system processes the data gathered in an algorithm, multiplying your safety, comfort and dynamism several times over. Reflection is the better form of reaction.



Sight machine.



As soon as it gets dark, the eyes of the new S-Class come to life. The optional LED High Performance headlamps go into fully automatic action and reaction, illuminating with precision the areas where they're needed, exactly when they're needed. You can even opt to take the shine off oncoming traffic if you want to avoid dazzling other road users. This gives you optimum vision in practically every driving situation – and above all, a good feeling about where you're headed.





Where the best deals are done.



Catapulting your career.





A detailed view of the interior of a Mercedes-Benz S-Class AMG. The image shows the driver's side door panel, the dashboard, and the center console. The door panel features a large, illuminated speaker and a door handle. The dashboard has a diamond-quilted leather pattern and circular air vents. The center console has a gear shifter and handbrake. The overall aesthetic is one of luxury and performance.

It takes three extraordinary letters to crown an S-Class: AMG, the fastest way to the top. High-performance technologies which have earned their spurs in motor racing are matched with systematically deployed lightweight materials. The result is a unique combination of luxury saloon and super sports car: the S 63 AMG. As it is with the technologies, so it is with the materials: only the best, the truly special are used. Carbon fibre, for example – a material that, thanks to its minimal weight and extreme rigidity, is extensively deployed in Formula 1 racing. Precisely fashioned and finished by hand, it gives the interior of the S 63 AMG an air of exclusive sportiness.



Mercedes-Benz Intelligent Drive. Looking ahead. Thinking ahead.

Welcome to the automotive future. Which arrived a long time ago as far as the S-Class is concerned. Lay your hands on the steering wheel and all your senses will link up. The cutting-edge on-board and external sensor systems will see ahead for you, draw conclusions for you, react at lightning speed and thereby prevent accidents. Thanks to radar sensors, a stereo camera, powerful processors and technical assistant systems. And years

of unstinting research. A further milestone from Mercedes-Benz along the path towards greater safety and comfort in road transport and a significant step towards autonomous driving. What will the future bring? The more research we do, the more perspectives that open up. That's how it is with visions. There comes a time when you need a new one. Of and for the future.

Just a second!



A blurred city street scene with cars and buildings, suggesting motion and technology. The image is split into two color zones: a warm, golden-yellow left side and a cool, blue right side. The background shows a city street with cars and buildings, all blurred to convey a sense of speed and motion. The text is overlaid on the right side of the image.

Everyone has a view on whether it's possible to predict what's coming. Impossible, many would say. A challenge, is what our R&D people reply. But actually, our engineers were not happy with just seeing what's about to happen: they had the crazy idea of wanting to influence the future through actions in the present, for in this way they could help to prevent accidents ever happening. You've surely been there before: you are concentrating on the road ahead, when suddenly a shadow catches the corner of your eye ... In those few critical seconds you're best off benefiting from the results of many years of research. We have developed technologies that allow the vehicle to keep an eye on everything around it. It can see things coming that we can at best only guess at – for example, by calculating where moving objects will move to, and when. Using a stereo camera system that can view things three-dimensionally, in other words spatially. Just like a human can. But the camera system can then compute this data so quickly that it is analysed in real time, and can forecast, for example, the future position of a cyclist.

Masterpiece of chassis engineering.

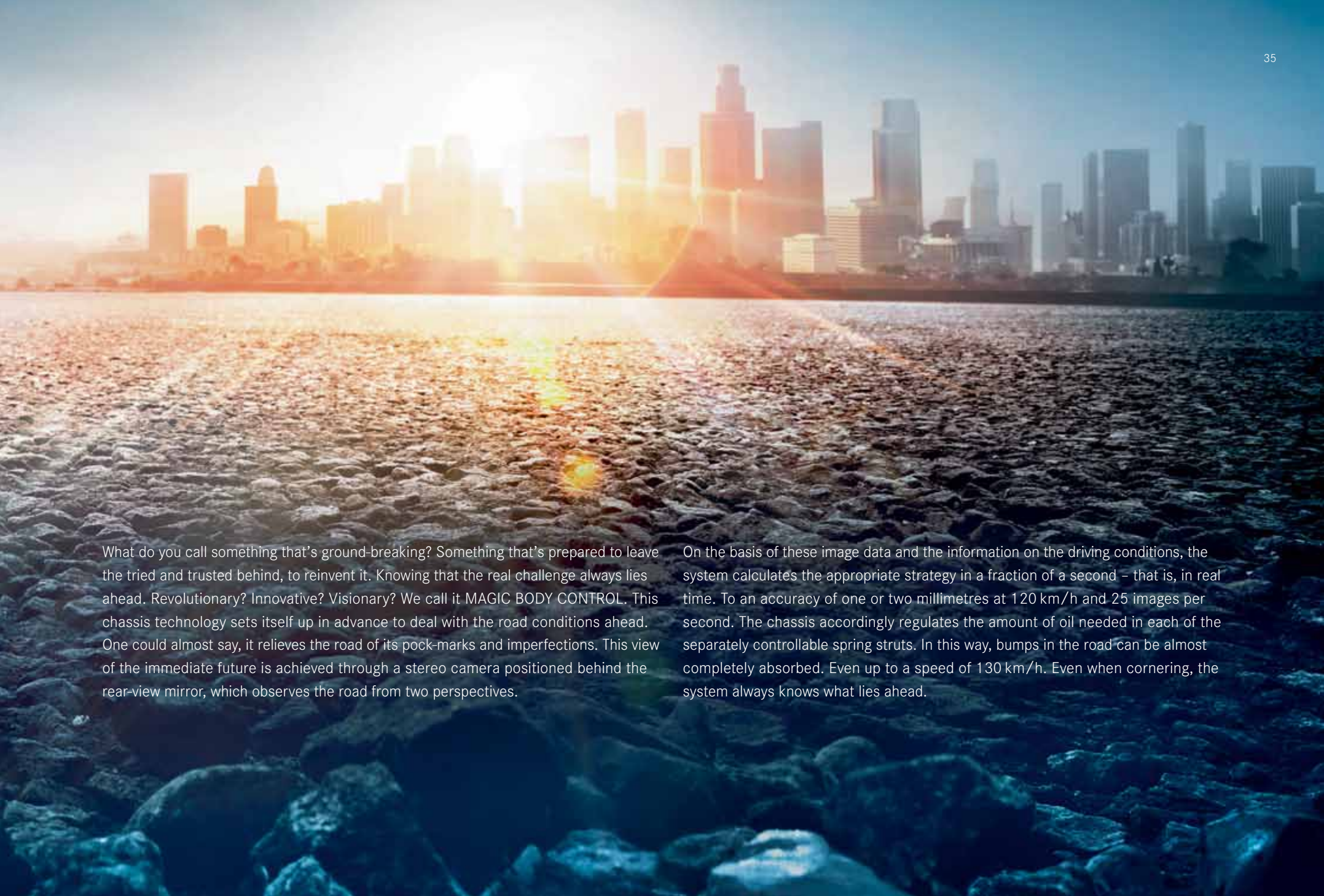

A city skyline is visible in the background, silhouetted against a bright sunset. The sun is low on the horizon, creating a strong lens flare and illuminating the water in the foreground. The water is dark with many small, shimmering ripples. The sky is a mix of orange and blue.

What do you call something that's ground-breaking? Something that's prepared to leave the tried and trusted behind, to reinvent it. Knowing that the real challenge always lies ahead. Revolutionary? Innovative? Visionary? We call it MAGIC BODY CONTROL. This chassis technology sets itself up in advance to deal with the road conditions ahead. One could almost say, it relieves the road of its pock-marks and imperfections. This view of the immediate future is achieved through a stereo camera positioned behind the rear-view mirror, which observes the road from two perspectives.

On the basis of these image data and the information on the driving conditions, the system calculates the appropriate strategy in a fraction of a second – that is, in real time. To an accuracy of one or two millimetres at 120 km/h and 25 images per second. The chassis accordingly regulates the amount of oil needed in each of the separately controllable spring struts. In this way, bumps in the road can be almost completely absorbed. Even up to a speed of 130 km/h. Even when cornering, the system always knows what lies ahead.

When you're driving in the S-Class, arriving is almost incidental. Both for you and our engineers, too. Their aim for every journey is to create a space which becomes yours when you move into it. In a seat that cools you or warms you as desired, and gently tilts backwards until, relaxed and stretched out in the back, you rediscover the true meaning of spaciousness. The measure of all things, which adjusts itself to you, supports your legs and bolsters your back. From the six massage programs available, you select

15 therapeutic minutes – relaxing you after what has been, reviving you for what's still to be done. In an exclusive workplace that offers all you need to make you independent. You will find the unobtrusive technologies at work here, which turn your trip into one of incomparable comfort, intuitive to operate. And when you do get out, you are not just getting out of a car, but of a space specially created for you: the S-Class



First-Class Business Class.



Light has never been so focused.





There is not much we don't try in our quest to revolutionise every area of automotive engineering and be the first to bring new technologies to the road. So why not put light in the spotlight, and work on it until it is efficient and intelligent enough to be fit for an S-Class? And we don't just mean that the LED-based lighting technology must illuminate the road surface better, the light temperature must be agreeable and the lights must use less energy compared to conventional headlamps. S-Class lighting must do more than that. It must interact with the various sensor and assistance systems, such as optional

Adaptive Highbeam Assist. With the result that if an oncoming vehicle or a vehicle ahead is detected, the area it occupies is simply blanked out in the main beam light cones of the LED headlamps. And when at a standstill, at traffic lights for example, the brake light is automatically toned down so as not to dazzle anyone behind. The more than 190 single-chip LED diodes ensure even greater comfort and safety in traffic. So, light can do a whole lot more than just be illuminating. In a Mercedes-Benz, at least.

What makes a car a Mercedes?

Deep-rooted traditions: in our case, it is innovative traditions that run deep. We have continually gone down previously uncharted avenues. Milestone by milestone. These ventures spawned the first vehicle with a crumple zone, the first ABS, the first diesel car. The first automobile. But rather than wallowing in the past, let us look to the future.

Mercedes me – welcome to a world that revolves around you. People are our primary concern. With this in mind, we have developed a new platform for your personal contact with Mercedes-Benz. With individual services tailored especially to your needs. “connect me” links up the vehicle to your individual world, to everything that is important to you. “move me” offers new mobility solutions. And “inspire me” provides an exclusive insight into the future of mobility. Your point of access to a world of fascination: www.mercedes.me



Mercedes-Benz Intelligent Drive – on the road to accident-free driving. We develop intelligent technologies which actively support the driver and noticeably relieve the driver’s workload. Valuable assistants are already available in your Mercedes-Benz today: automatically helping to keep the car at a safe distance from the vehicle in front, braking when necessary and warning the driver of impending rear-end collisions or of vehicles in the blind spot. The sensor technology of the driving assistance and safety systems is intelligently interlinked. Potentially dangerous situations are identified earlier than ever – and ever more frequently avoided as a result. Discover the fascinating world of Mercedes-Benz Intelligent Drive at www.mercedes-benz-intelligent-drive.com

BlueEFFICIENCY – our vision of emission-free driving. Sustainability is a big word to which we lend real meaning in all that we do, down to the smallest details. From minimising the environmental impact of our production operations to alternative drive concepts.

We have major goals in our sights. What better than to achieve them on a long drive in a Mercedes?

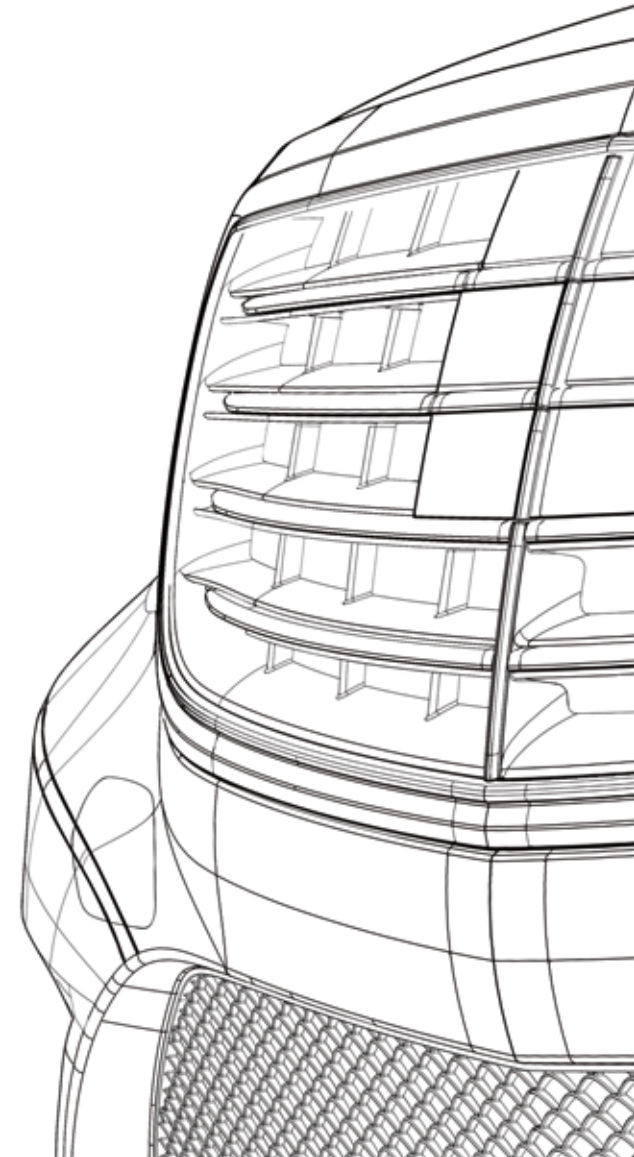

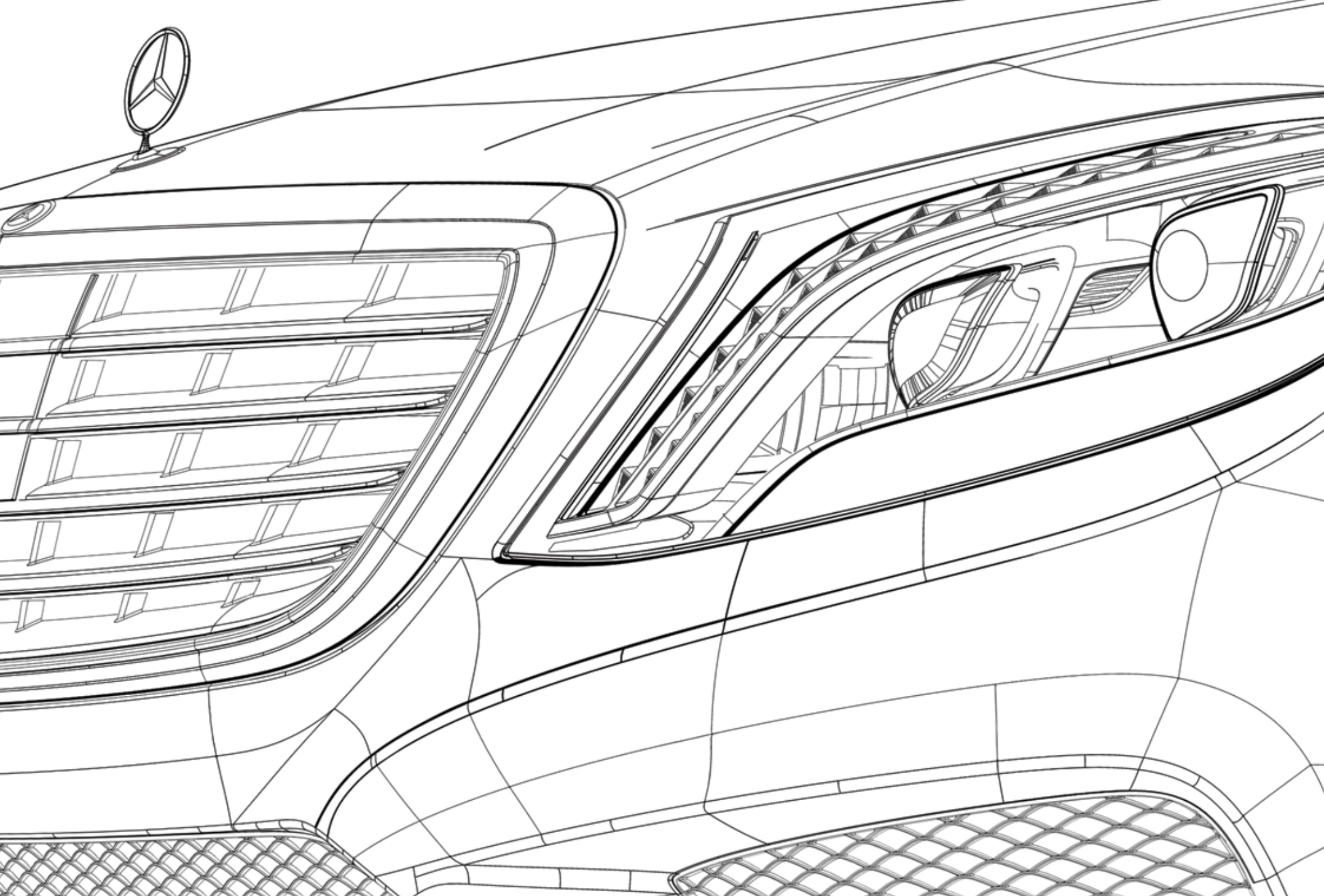

Diesel and petrol engines.

The rule of the road today: you can't have refinement without efficient technologies. Mercedes-Benz diesel and petrol engines are therefore lighter and measure out fuel extremely precisely. Whatever system you opt for, they bring together a sense of responsibility and commitment without compromising on driving enjoyment.

V6 engine. Fuel consumption in the S 350 BlueTEC can be as low as 5.5l per 100 km with an output of 190 kW (258 hp) and peak torque of 620 Nm. CO₂ emissions are just 155–146 g/km. Plus the BlueTEC technology in the 6-cylinder engine reduces nitrogen oxide emissions substantially, meaning that the S 350 BlueTEC already meets the strict requirements of the Euro 6 emissions standard.

V8 engine. Refinement, driving pleasure and responsibility – embodied by the petrol engine with 335 kW (455 hp). Thanks to twin turbocharging and intercooling, the S 500 has huge reserves of power and can accelerate from 0 to 100 km/h in only 4.8 seconds. The engine may give off its typical, unmistakably sonorous and cultivated sound, but fuel consumption stays exceptionally low.

V12 engine. As the pinnacle of the engine range the V12 biturbo engine combines fast responsiveness with environmental awareness: it meets the requirements of the Euro 6 emissions standard and features the ECO start/stop function. This is how the V12 engine saves fuel – yet is generous with superlatives: 830 Nm of torque is on tap from below 2000 rpm. Its 390 kW (530 hp) accelerate the vehicle from a standstill to 100 km/h in a mere 4.6 seconds.

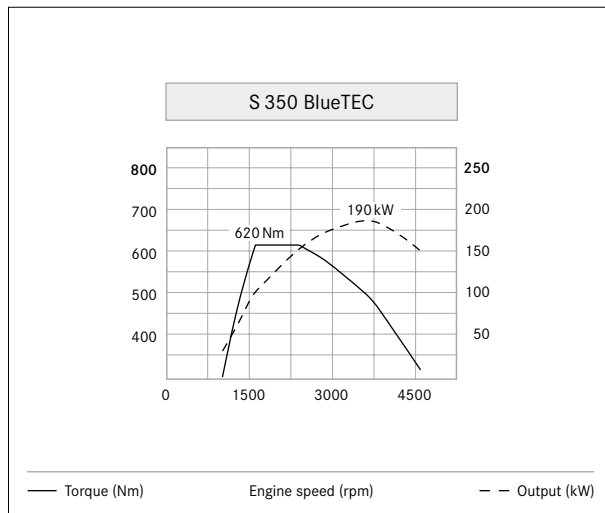

The 6-cylinder diesel engine combines high output with low fuel consumption.

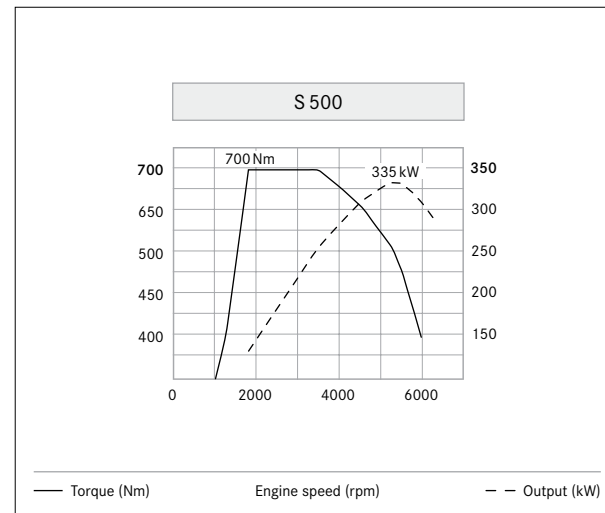

The 8-cylinder petrol engine is powerful, refined and efficient.

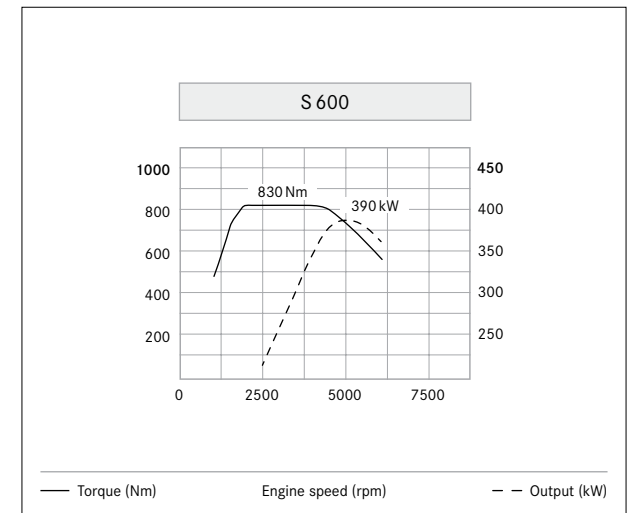

The 12-cylinder petrol engine – supreme power delivery, maximum efficiency.

S 300 BlueTEC HYBRID and S 400 HYBRID.

The particularly efficient and environmentally responsible drive systems combine an internal combustion engine with an electric motor. The interaction of the engines is controlled by high-performance, intelligent electronics. If the vehicle brakes, the electric motor becomes an alternator and produces electricity for the lithium-ion battery.

Environmentally responsible, comfortable and dynamic, all at the same time – that is what is expected of a drive system for the luxury class. In the S 300 BlueTEC HYBRID, Mercedes-Benz combines the 2.2-litre 4-cylinder diesel engine generating 150 kW (204 hp) with a powerful hybrid module. Combined fuel consumption can be as low as 4.4l per 100 km. These figures are possible thanks to efficiency-enhancing measures such as intelligent lightweight construction, tyres with low rolling resistance and a drag coefficient (c_d value) of 0.23.

In the S 400 HYBRID, the enhanced 6-cylinder petrol engine is supplemented by a compact, lightweight and torquey hybrid module which is driven by a high-capacity lithium-ion battery. This drive system delivers an output of 225 kW (306 hp) and, in combination with the hybrid module, allows fuel consumption as low as 6.3l per 100 km.

The S 350 BlueTEC and S 400 HYBRID already meet the requirements of the Euro 6 emissions standard. Furthermore, both engines fulfil the strict criteria of efficiency class A and, in the case of the S 300 BlueTEC HYBRID, even class A+.

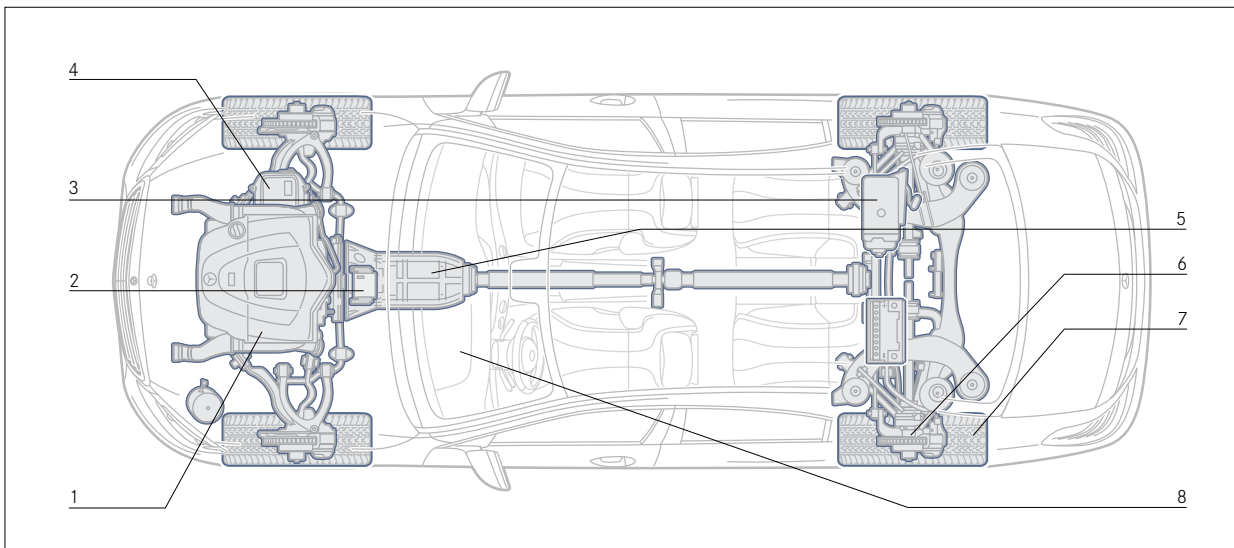

- 1 Efficiency-optimised 4-cylinder diesel engine with 2.2-litre displacement (S 300 BlueTEC HYBRID) or 6-cylinder petrol engine with 3.5-litre displacement (S 400 HYBRID).
- 2 The compact hybrid module is located between the internal combustion engine and the automatic transmission.
- 3 The powerful lithium-ion battery has a high energy density yet its dimensions are compact and it is light in weight.
- 4 The power electronics coordinate the intelligent and efficient work performed by the internal combustion engine and electric drive system.
- 5 The 7G-TRONIC PLUS automatic transmission ensures imperceptible switching between the power sources and acceleration without interruption of tractive power.
- 6 Recuperative braking system: when braking, the electric motor becomes an alternator and produces electrical current for the lithium-ion battery.
- 7 Tyres with low rolling resistance for comfortable and economical motoring.
- 8 The energy flow and drive system battery charge level are indicated constantly on the hybrid display.

Transmissions.

The consumption- and efficiency-optimised 7G-TRONIC PLUS automatic transmission stands out by virtue of its high level of efficiency, ultra-smooth gear changing, dynamic response and reduced noise levels.

7G-TRONIC PLUS. This 7-speed automatic transmission combines a high level of comfort with driving pleasure and efficiency. The seven forward gears allow a wide ratio spread with low engine speed increments between the individual gears. This leads to fast-responding, fuel-efficient gear changes with pleasantly smooth transitions. As 7G-TRONIC PLUS is able to skip individual gears, multiple downshifts are possible for fast and powerful sprints. The shift characteristics can be preset from economical to dynamic with the transmission modes “Economy”, “Sport” and “Manual”. In “Manual” mode, drivers with sporty inclinations can switch gears manually using the DIRECT SELECT steering wheel gearshift paddles – as in motorsport.

DIRECT SELECT. The DIRECT SELECT gearshift includes the DIRECT SELECT lever on the steering column which serves to change between P, R, N and D. It is additionally possible to shift gear manually using the DIRECT SELECT shift paddles.



DIRECT SELECT lever on steering column. The driver can also change up or down a gear manually using the additional shift paddles.

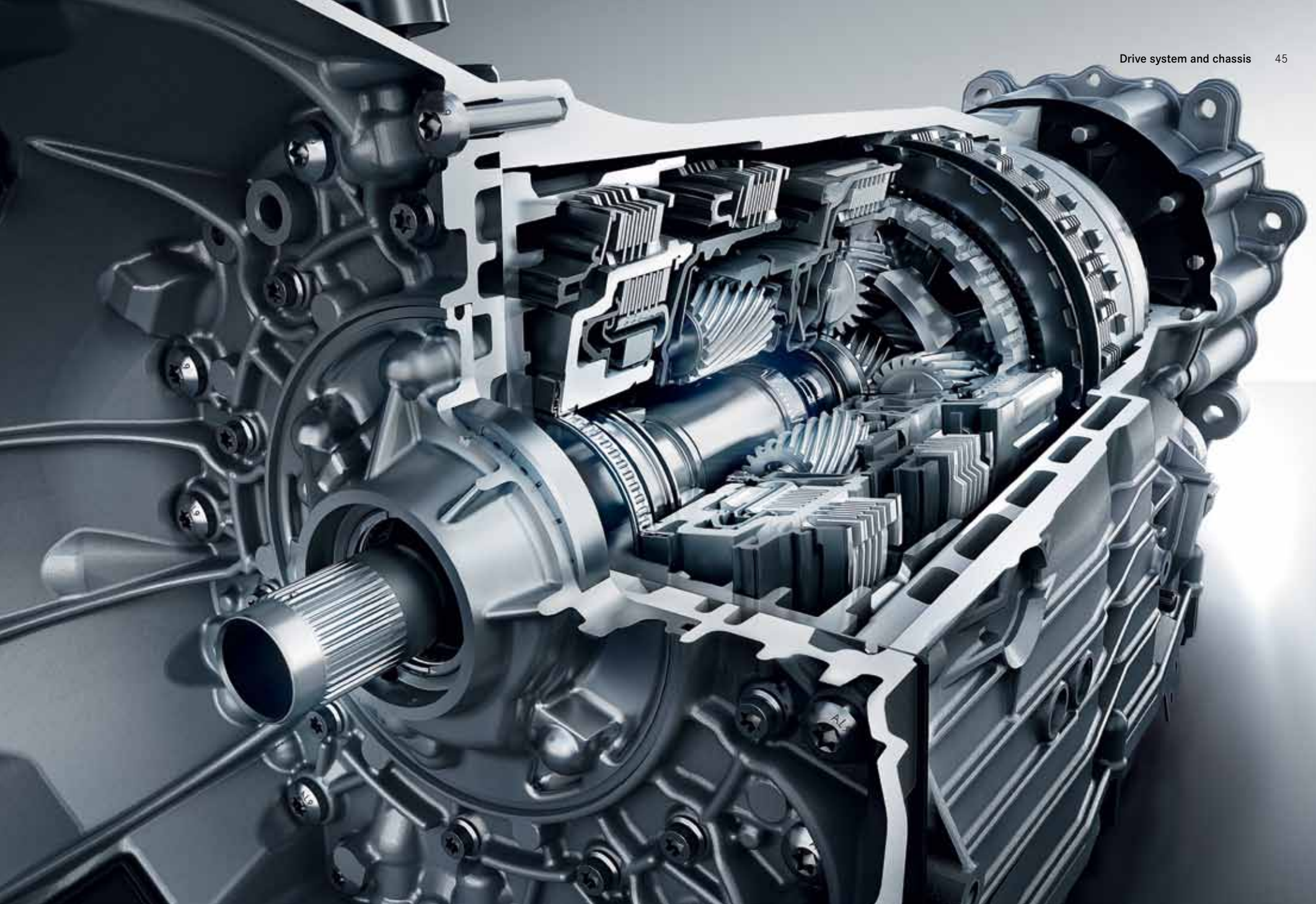

Chassis and suspension.

The S-Class is fitted with the latest-generation, enhanced AIRMATIC suspension system as standard. The innovative MAGIC BODY CONTROL – a technological milestone, premiered in the S-Class – is available as an alternative.

AIRMATIC (standard). In combination with variable damper control, the air suspension system ensures ride comfort and dynamic handling at a very high level. The damping at each wheel is adapted to the current driving situation, and can be set for more comfortable or sporty characteristics as required.

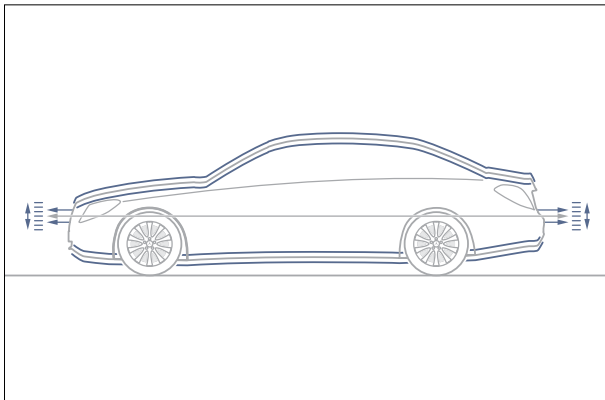

AIRMATIC air suspension ensures comfort and agility through its ability to raise and lower the suspension settings as required.

Crosswind Assist (standard). In strong, gusty crosswinds there is a danger of the vehicle being blown off course. Crosswind Assist is able to recognise this and help the driver to keep the vehicle on course. Using the ESP® sensors, course-correcting braking intervention is performed automatically. This braking intervention takes place at the wheels on the side of the vehicle facing the crosswind. The resulting yawing motion around the vertical axis counters the effect of the crosswind. This reduces track offset considerably. In this way Crosswind Assist gives the driver a greater feeling of safety and helps to avoid inappropriate reactions, especially when sudden gusts strike the vehicle.

MAGIC BODY CONTROL (option). This dynamics-oriented suspension system already adjusts to surface undulations before the vehicle drives over them. This is made possible by the combination of the active springing of the suspension system with the ROAD SURFACE SCAN function. With the aid of a stereo camera the condition of the road surface ahead is captured in detail. From the data gleaned the system calculates in a split second the correct strategy for adjusting in advance the damping of each wheel so as to deal in the best possible way with the unevenness ahead.



Integral safety concept.

We are driven by our vision of accident-free motoring. Our integral safety concept brings us a step closer to achieving this aim – a holistic approach which paves the way for new synergy-based technological solutions such as “Mercedes-Benz Intelligent Drive”, which combines comfort and safety.

As the inventor of the car we feel that we have a special responsibility for road safety. This is why we are the first car manufacturer to have developed an integral safety concept which seamlessly blends measures to enhance active and passive safety. The holistic approach is subdivided into four phases and offers safety solutions for every situation. It includes systems for safe driving which help to avoid risks by warning you and coming to your aid in good time. Our unique PRE-SAFE® system kicks in in the event of danger and activates anticipatory measures for occupant protection. If a collision should still occur in spite of all the preventive measures, further technologies ensure protection as needed. We have also borne in mind the time immediately following an accident and developed solutions which can help prevent worse and facilitate rapid help. A selection of these technologies for the “Safe driving”, “In the event of danger”, “In an accident” and “After an accident” phases is presented on the pages which follow.

Safe driving: Driving Assistance package Plus (option).

This package comprises numerous safety and assistance systems such as DISTRONIC PLUS with Steering Assist and Stop&Go Pilot, the PRE-SAFE® Brake, Brake Assist BAS PLUS with Cross-Traffic Assist, Active Blind Spot Assist, Active Lane Keeping Assist and PRE-SAFE® PLUS. These Mercedes-Benz Intelligent Drive technologies help to relieve driver strain, reduce the risk of accidents and improve protection for both the occupants and other road users.

DISTRONIC PLUS with Steering Assist and Stop&Go Pilot helps the driver to keep a safe distance from the vehicle in front and also to remain in the centre of the lane. In this way, the system provides a great deal of stress-relieving comfort, especially on long journeys and when following vehicles in a traffic jam. Brake Assist BAS PLUS with Cross-Traffic Assist and PRE-SAFE® Brake can reduce the risk of accidents at junctions, rear-end collisions and collisions with pedestrians, particularly in urban traffic.

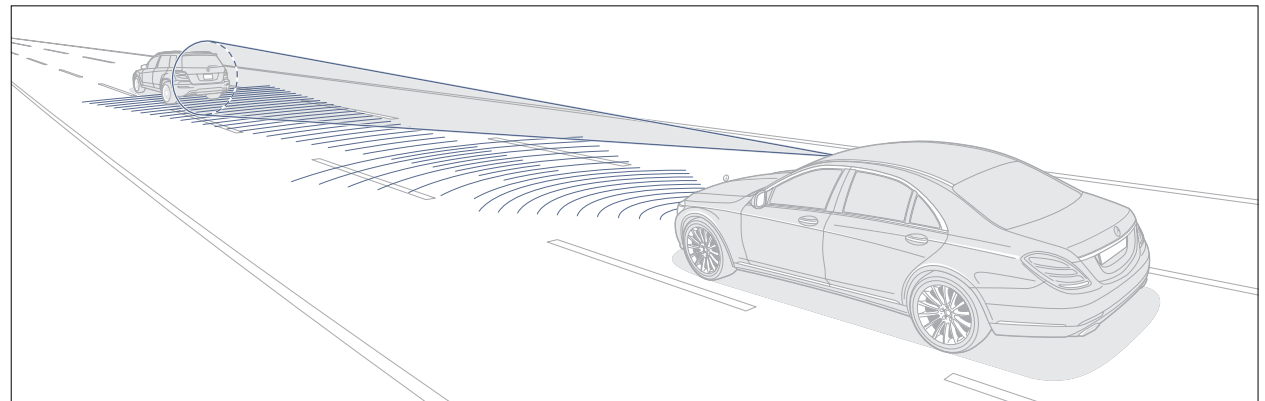

DISTRONIC PLUS with Steering Assist and Stop&Go Pilot takes the strain off the driver in both moving and stop-and-go traffic.

Active Lane Keeping Assist and Active Blind Spot Assist provide assistance if the vehicle leaves its lane unintentionally or during lane changes when there is a danger of collision with other vehicles. One-sided braking intervention can help return the vehicle to its lane and prevent an accident. PRE-SAFE® PLUS extends the functions of the PRE-SAFE® occupant protection system with preventive measures when a rear-end collision threatens.

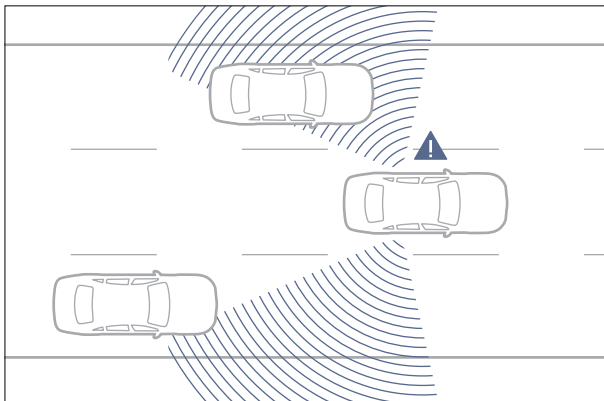

Active Blind Spot Assist monitors the difficult-to-see areas to the left and right of the car.

Safe driving: Night View Assist Plus (option). Only 20 percent of all traffic travels at night, yet 40 percent of fatal accidents occur during this time. Night View Assist Plus makes it possible for the driver to spot people or animals sooner in the dark. They are clearly shown up in the multifunction display in the instrument cluster. A world first here is the combination of two infrared cameras which provide for a particularly high-resolution



Active Lane Keeping Assist can intervene to correct the vehicle's direction if it inadvertently changes lane.

image and a precise thermal image signature. The Spotlight function enables endangered pedestrians across the entire width of the road to be flashed at four times, so that the driver registers them even more quickly and the pedestrians themselves recognise the danger. As standard, the night view image only appears automatically when a hazardous situation is recognised.



Night View Assist Plus highlights any people it has recognised and helps the driver to react more quickly to dangers at night.

In the event of danger: PRE-SAFE® preventive occupant protection system (standard). The preventive occupant protection system is able to identify critical driving situations in advance and to activate safety systems by way of precaution. To this end, the PRE-SAFE® system continuously evaluates the data from systems such as ESP® and BAS, enabling it to identify driving situations such as oversteer/understeer and emergency stops. If a critical driving situation is detected, in a fraction of a second the belts on the front seats can be reversibly tensioned and the side windows automatically closed, so that the belts and airbags are able to deploy their full protective effect should an impact occur.

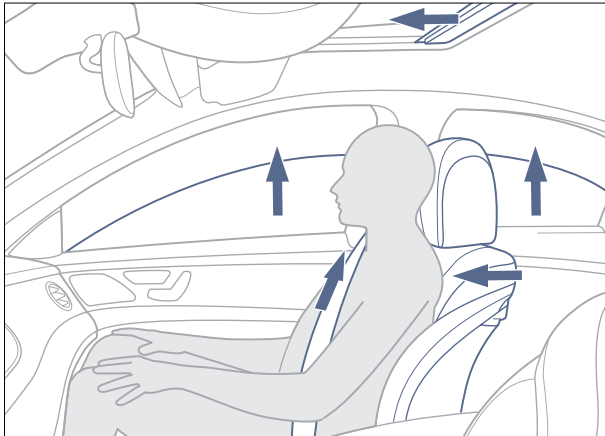

The PRE-SAFE® anticipatory occupant protection system can mitigate the consequences of accidents.

In the event of danger: PRE-SAFE® PLUS (part of the optional Driving Assistance package Plus). If a rear-end collision threatens when at standstill, this extension of the PRE-SAFE® system is able to initiate additional preventive occupant protection measures. These include warning the following traffic by activating the rear hazard warning lights at high frequency and locking the vehicle brakes when at a standstill if the driver indicates that they wish to remain stationary.

In the event of danger: BAS PLUS with Cross-Traffic Assist (part of the optional Driving Assistance Plus package). The BAS PLUS anticipatory Brake Assist system determines the necessary brake pressure to avoid a collision or reduce the severity of an impending accident and, if the level of brake force applied by the driver is too weak, provides the necessary level, if necessary right up to full brake application. BAS PLUS is also able to intervene to provide support in situations involving crossing vehicles. The system also recognises pedestrians in the area in front of the vehicle and can boost the driver's braking as necessary here as well.

In the event of danger: PRE-SAFE® Brake with pedestrian detection (part of the optional Driving Assistance package Plus). PRE-SAFE® Brake assists the driver in convoy traffic (vehicles ahead or stationary obstacles) when a rear-end collision threatens and the driver shows no responses to counter the danger. The aim is to warn an inattentive driver of an imminent rear-end collision. PRE-SAFE® Brake obtains its situational information from onboard long-range and short-range radar sensors. It additionally allows detection of pedestrians when used in conjunction with a stereo camera. This means that collisions with pedestrians can be avoided up to a speed of 50 km/h.

In an accident: PRE-SAFE® Impulse (standard). During a frontal impact the driver and front passenger are subjected to very high loads. In the early phase of a frontal impact, PRE-SAFE® Impulse tensions the seat belts of the front seats. In the process the front seat occupants are accelerated against the direction of the impact and drawn more deeply into their seats. When the peak loads occur, this retraction is relaxed as a controlled process. Pre-acceleration and force limitation enable the occupants to be temporarily isolated from the crash. This allows PRE-SAFE® Impulse to significantly reduce the risk of injury.

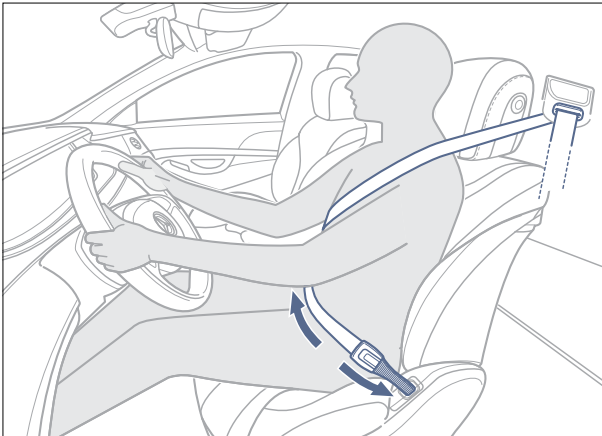

PRE-SAFE® Impulse: the seat belts can move the front occupants away from the collision direction in the early stages of a frontal impact.

In an accident: airbags (standard). The S-Class has eight airbags as standard in total. In addition to the impact bags, there are sidebags and windowbags for the driver and front passenger. There are also sidebags in the rear and optional beltbags for the outer rear seats. The beltbag, a type of inflatable belt strap, reduces the load exerted on the chest during a crash. If there is an accident, the beltbag strap inflates to almost three times its normal width. The loads acting on the occupants are distributed over a wider area, correspondingly reducing the loads on the chest area.

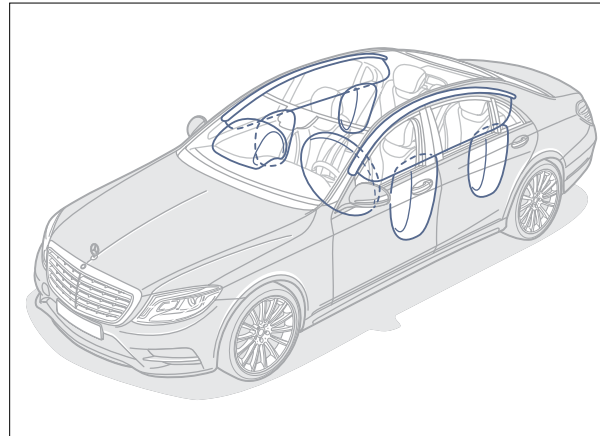

A total of eight airbags as standard can protect you and other vehicle occupants in the event of an accident.

After an accident: Mercedes-Benz emergency call system. This system is able to send an automatic emergency call using a working mobile phone connected to the vehicle as soon as the restraint system recognises an accident. At the same time it communicates GPS positional data and other information to the Mercedes-Benz emergency call centre. Then a voice connection is established, which can be in the relevant national language in practically all countries. This makes it easier to initiate rescue, recovery or towing to a Mercedes-Benz service outlet within a short time.

Measures after an accident. In order to mitigate consequential damage and, where necessary, expedite the rescue of the occupants, Mercedes-Benz has developed further measures. These include automatic engine cut-off, for example, or activation of the hazard warning lamps and interior emergency illumination. The central locking opens automatically, and crash joints between the door and the wing make it easier to open the doors after a frontal impact. Mercedes-Benz also provides multi-lingual rescue guidelines which emergency services can download online worldwide at www.mercedes-benz.de/rettungsfaden. As you can see, Mercedes-Benz offers well-thought-out safety whatever the situation.

Assistance systems.

The S-Class does not just influence its surroundings – it records them, with short- and long-range radar, stereo and infrared cameras and ultrasound sensors working together to give all-round vision, thereby making driving safer and more relaxing.

Stereo camera (option). This can capture objects and pedestrians passing in front of the car and calculate the path they will take. Intelligent algorithms evaluate the data and, for a large area of vision, can recognise and allocate in terms of space vehicles, pedestrians and different types of traffic signs and road markings that are oncoming, moving ahead or crossing the path of the car.



The stereo camera continuously monitors and evaluates what is happening in front of the vehicle.

360° camera (option). This system allows you to park and manoeuvre, giving you an all-round near-real-time view using four networked cameras. The vehicle and its surroundings can be displayed in a bird's-eye view on the COMAND Online display, and obstacles below the level of the windows are also displayed to the driver.

Parking package (option). Active Parking Assist with PARKTRONIC assists when searching for a parking space and when entering or leaving parallel or end-on parking spaces. When activated, it automatically steers the vehicle into a parking space, relieving the driver of the work of steering and braking. When the driver engages reverse gear and confirms the suggested parking space, Active Parking Assist automatically carries out the steering manoeuvres up to a speed of 10 km/h. The driver only operates the accelerator and brake pedal, and the parking procedure is completed after a maximum of seven manoeuvres.

Traffic Sign Assist¹ (part of COMAND Online). This driving assistance system can detect and recognise speed limits, “no-overtaking” signs and the respective signs signalling their end, and display these in the instrument cluster and the map view of the COMAND display. If the driver attempts to drive into a street or carriageway with a “no-entry” sign, for instance a motorway access road, the instrument cluster will display a visual warning and an acoustic warning will be emitted (wrong-way warning function).

LED Intelligent Light System (option). For the best possible visibility on country roads and motorways, when cornering, on bends and in foggy conditions, the low-beam headlamps of the LED Intelligent Light System automatically adapts to the weather, lighting and driving conditions. Adaptive Highbeam Assist Plus allows continuous long-range illumination of the road ahead without dazzling oncoming traffic or vehicles ahead. Plus the high beam is dimmed automatically for road signs that reflect its light back strongly. The LED Intelligent Light System thus makes a key contribution to safe driving.

¹ The Traffic Sign Assist system is configured on a country-specific basis.

Warmth Comfort package (option). On cold days the Warmth Comfort package provides cosy warmth in next to no time. The armrests on the centre console and the doors can be heated in addition to the seats. The armrest in the middle rear seat can be additionally heated if electrically adjustable rear passenger seats are fitted. Driver, front passenger and passengers on the outer rear seats are able to choose between three different heating levels at the touch of a button. The surfaces to be heated can be selected via COMAND Online. Additional highlight: the heated steering wheel.



With the Warmth Comfort package, the vehicle occupants can each choose one of three heat settings.

Touchpad (option). Something else for your hands to look forward to in addition to the steering wheel: the touchpad allows you to control telematics functions using one or two fingers. Plus letters, numbers and symbols can be entered using natural handwriting. Furthermore, there are three touch-sensitive keys behind the pad, which can be used to control important functions quickly and directly. The touchpad is therefore an additionally innovative and fully featured additional entry option alongside the COMAND Controller and LINGUATRONIC.



The touchpad allows convenient control of telematics functions using one or two fingers.

Head-up display (option). In addition to your destination, you now see in front of you everything of importance relating to the route that takes you there: the head-up display posts information such as the car's speed, speed limits and navigation instructions within your field of vision. A special light sensor optimises the legibility of the display whatever the light conditions. The image height is customisable, as are the various display contents, which you can activate or deactivate as required.



The head-up display posts information directly within the driver's field of vision.

Multimedia systems.

On your way to work or already in the thick of it? Individual media requirements and options have already been taken into account in the S-Class.

COMAND Online (standard). Navigation, telephone, audio, video, internet – with the COMAND Online control and display system the driver keeps these and many other functions in sight and under control. Information is shown on a 31.2 cm high-resolution colour display. Operation is simple and intuitive. Fast hard-disc navigation with realistic topographical map display for relaxed route guidance.

In combination with an appropriate mobile phone, it is possible to call up internet sites when the vehicle is stationary and to use Mercedes-Benz Apps such as POI search, weather or internet radio while on the move. The integral WLAN hotspot also allows integration of a notebook or tablet PC. A DVD player, radio, 10 GB memory for audio and video files and interfaces for connecting external devices provide made-to-measure entertainment.

Live Traffic Information¹ (part of COMAND Online). This service allows the reception of up-to-date and precise traffic information in real time for optimised dynamic route guidance and a more accurate estimated time of arrival. Data transfer is via a communication module which provides the internet connection with its own SIM card including data roaming.



The optional handset with touchscreen serves both as a telephone and as a remote control for the seat functions of the optional Rear Seat Comfort package.

Burmester® high-end 3D surround sound system (option). 24 high-performance loudspeakers, 24 amplifier channels with a total system output of 1540 watts and technologies developed exclusively for the vehicle guarantee unprecedented listening enjoyment. The combination of analogue and digital elements produces an extraordinarily expressive and fascinating 3D sound. In addition to the acoustic highlights, the Burmester® high-end 3D surround sound system impresses with visual effects: two tweeters installed in the mirror triangles of the front doors move into the most favourable position when the system is switched on, lighting up in one of seven freely selectable colours if the ambient lighting is active.

Burmester® surround sound system (option). 13 high-performance loudspeakers and electronic and acoustic elements which have been precisely aligned to the vehicle interior provide the first-class Burmester® feel-good sound. The sound experience can be further intensified with the surround function or the sound optimisation for the front and rear seats.

¹ 3 years of free use, available in 12 countries.

SPLITVIEW (option). The 31.2 cm COMAND Online display enables the front passenger to enjoy films in brilliant picture quality while the driver follows the navigation instructions, for example. This is made possible by SPLITVIEW, which is able to show different content simultaneously on the same display depending on the viewing angle. A high-quality radio headset treats the

front passenger to first-class sound without disturbing the driver. The front passenger has convenient access to the entertainment source of his or her choice by remote control – movies on DVD, radio, internet or television in conjunction with a TV receiver. Content from MP3 players, game consoles or an iPod® is also available via the Aux-in socket.

Individual Entertainment in the rear (option). DVD films, internet, video games, music – the Individual Entertainment system gives passengers in the rear their very own personal entertainment programme. Two 25.4 cm displays and radio headphones for brilliant picture and sound quality.



SPLITVIEW displays two different images at the same time – for the driver and front passenger – on a single screen in the centre console.



Part of the Individual Entertainment in System the rear: the 25.4 cm displays.

Seats.

Sitting in the S-Class is not just comfortable, it can also increase your ability to keep driving well. Quite apart from individually climatized seats plus 60 possible settings from the seating area through to the steering column, there is a massage function and a special relaxation cushion for the rear seat.

ENERGISING massage function (option). Six different programs are available, including two hot relaxing massage programs, which can relax, stimulate or mobilise you according to your wishes, and which can be selected for both the front and the rear seats. “Strong” or “weak” intensity levels can be set. The speed and effect vary according to the program. Each program lasts between 12 and 15 minutes.

Climatized front and rear seats (option, standard for S 600 and S 65 AMG). The active ventilation function of the climate-controlled seats rapidly cools the seat surfaces to a pleasant temperature. On cold days the on-demand seat heating provides cosy warmth as required. Seat ventilation and seat heating can be independently set in three stages at the touch of a button.

Memory package (option, standard for V8 and V12 engines). If the driver and front passenger change places frequently, the Memory package offers particular operating convenience. Up to three different positions for the power front seats, steering column and exterior mirrors can be saved and retrieved at the touch of a button.

First-Class rear suite (option). The continuous Business console transforms the rear into a mobile office with two individual seats. Two USB connectors, two 12-volt sockets and two temperature-controlled cup holders, as well as optional features such as folding tables, make for a comfortable travelling and working environment.

Executive seat (option). With the Executive seat the rear-seat passenger behind the front-passenger seat can enjoy even long journeys in absolute relaxation. The seat can recline into a comfortable lying position at the push of a button. The combination of thigh support and footrest creates a comfortable bed.

Chauffeur package (option). The front passenger seat can be electrically moved further forward by up to 77 mm. This enables the passenger seated behind it to enjoy the journey even more. The noticeably longer legroom allows a more comfortable resting position. This is assisted by an electrically extending footrest.



Optimum seating comfort in the outer rear seats.

Light and climate control.

Perfection means attending to everything, even the air. The AIR-BALANCE package ionises the air and cleans and scents it with one of four atmospheric fragrances, if so desired. In this way, it does not need to be down solely to the ambient lighting to create a first class relaxing or stimulating S-Class atmosphere.

Ambient lighting (option, standard for the long-wheelbase version and the S 500). With its pleasant and indirect light, the ambient lighting creates a unique feeling of well-being throughout the whole of the interior. Seven different colours and five dimming levels are available to create a personalised lighting mood.

AIR-BALANCE package (option). The vehicle interior can be fragranced to preference with the AIR-BALANCE package. There is a choice of four high-quality interior fragrances according to personal preference and mood. In addition, the air quality can be improved by oxygen ionisation and filtering of the incoming air.

THERMOTRONIC automatic climate control (standard). With two climate zones and three air flow settings, the automatic climate control creates an individual climate of well-being on board. The driver and front passenger can set their temperatures independently of each other. There are five different and separate settings for the temperature of the footwells in the front. An active carbon filter for particulate matter keeps dust, soot and pollen at bay and reduces smells and pollutants in the air.



Ambient lighting – lighting mood to suit personal tastes.

S 600.

Excellence – expressively showcased and impressively delivered: the S 600 with a V12 engine.

Seldom has performance been brought to the road with such aplomb. The S 600 has a V12 engine developing 390 kW (530 hp) for power delivery that appears to turn every moment into torque. But it is not just the power of the S 600 that leaves a lasting impression – its appearance does, too. Exclusive design elements such as the V12 radiator grille with a twin louvre and two visible tailpipes

in a V12 design further enhance the car's looks. In the interior, the V12 start-up screen plus V12 emblems on the seats and floor mats provide evidence of the car's extra power. In keeping with the refined interior, the S 600 is equipped with a number of exclusive assistance systems as standard, including MAGIC BODY CONTROL, the Driving Assistance package Plus and the LED Intelligent

Light System. Inside the car, the ambience is enhanced with the Exclusive package, the AIR-BALANCE package, the Exclusive trim package and the head-up display. A design which wins the S 600 admiring looks from those who are quick enough to see it as it flashes past.



Exclusive interior.



V12 radiator grille with twin louvres and chrome bars.





S 63 AMG exterior.

Power, endurance and speed are the calling cards of the S 63 AMG – as is evident from the first glance. Where the exclusivity of the S-Class is taken to an even higher level by the expressiveness of AMG.

The S 63 AMG is powered by a V8 biturbo engine with an output of 430 kW (585 hp) and 900 Nm of torque. It is recognisable by the “V8 Biturbo” lettering on the wing. Its power is controlled by an AMG SPEEDSHIFT MCT 7-speed sports transmission system with a Controlled Efficiency mode and an ECO start/stop function. AMG

sports suspension for the long-wheelbase version based on AIRMATIC ensures maximum comfort even when driving dynamically.

The athletic-looking saloon is characterised by its AMG-specific front and rear aprons and side skirts,

all with silver chrome trim. Black flics in the front apron provide optimum aerodynamics. The sporty AMG forged wheels, the high-performance braking system, comprising compound brake discs bearing the AMG logo and finished in grey, and the AMG sports exhaust system with two chromed twin tailpipes round off the stylish appearance.



The optional 20-inch AMG forged wheels with wheel bolt covers emphasise the exclusive appearance of the S 63 AMG.



The standard 19-inch AMG forged wheels.

S 63 AMG technology.

AMG means having a drive system what will surpass itself time and again. As demonstrated by the S 63 AMG: reduced emissions, lower fuel consumption and a further improvement in performance with an output of 430 kW (585 hp) and 900 Nm of torque.



The systematic use of lightweight materials has resulted in the S 63 AMG being 100 kilograms lighter than its predecessor. This was achieved through using carbon fibre and innovative materials, a lithium-ion battery and weight-optimised wheels and tyres, resulting in lowered consumption, lower emissions and even more dynamic driving characteristics. Front to rear axle power distribution of 1/3 to 2/3 provides the high level of driving dynamics and the vast driving pleasure so characteristic of an AMG model. It also improves handling on wet road surfaces, and effortlessly transfers the enormous AMG power to the road in dry conditions. The AMG SPEEDSHIFT MCT 7-speed sports transmission with a wet clutch helps to boost performance and is designed to be driven sportily – without any compromises on comfort.

Systematic use of lightweight materials and intelligent detailed solutions have made the S 63 AMG even sportier yet more economical than its predecessor.





S 63 AMG interior.

It took two and half years to develop the S-Class interior. The aim was to reconcile the demands of extremely ambitious drivers with those of extremely demanding designers.

The sporty appearance of the S 63 AMG continues on into its interior. The AMG-specific seats have been designed for a dynamic driving style and offer reinforced lateral support. AMG metal badges on the front and rear seats signpost the vehicle's pedigree. The standard-fit seats are upholstered in

nappa leather of the very highest quality, with contrasting topstitching. The optional Exclusive package takes the interior's athletic look a step further, with perforated Exclusive nappa leather in a dynamic diamond design. Sports pedals, the AMG steering wheel, AMG-specific

floor mats, AMG door sill panels and an analogue clock with an IWC design round off the sporty appointments.



The single seats in Exclusive nappa leather featuring a diamond design provide great comfort and plenty of space to allow you to enjoy the trip.



Embossed AMG badge in the centre console.

S 65 AMG.

The S 65 AMG – performance in its most exclusive form.

This design idiom needs just three letters to impress: AMG. The AMG bodystyling consists of a unique front apron with flics in high-gloss chrome, a rear apron with an insert in high-gloss chrome and side sill panels trimmed with high-gloss chrome. Only the eyes looking at these appointments shine more brightly.

An exclusive interior ambience is created courtesy of the finest leather and a lavishly finished trim. AMG sports seats in AMG-specific diamond design offer optimum lateral support. The AMG sports steering wheel is finished in nappa leather with an airbag cover in nappa leather and silver-coloured aluminium shift paddles.

The S 65 AMG is powered by an AMG V12 biturbo engine that combines great power with smoothness of operation. Its 463 kW/630 hp are good for a maximum torque of 1000 Nm. In fact, there may only be one thing that is more powerful than the AMG V12: your desire to drive it.



A sporty interior setting with AMG sports seats and AMG sports steering wheel.



The standard-fit AMG 20-inch multi-spoke forged wheel with optional AMG high-performance ceramic compound braking system.



AMG Performance Studio.

Sportiness that teases the eye: from the carbon-fibre ceramic braking system through to the illuminated AMG door sills, the AMG Performance Studio turns the already fit-looking S-Class into an out-and-out Olympian package.

The many appointments and equipment options offered by the AMG Performance Studio serve to make the S 63 AMG and S 65 AMG even more exclusive. An AMG ceramic high-performance compound braking system is available for the first time for the S-Class, for example. It not only ensures the shortest of stopping distances and outstanding resistance to fading, but also offers braking performance normally to be found in motorsport. The AMG carbon-fibre engine cover and red brake callipers also add to the sporty look and feel of the car. The AMG Exterior Carbon-Fibre package gives the S 63 AMG and S 65 AMG a sophisticated appearance with many high-quality carbon-fibre trim elements, such as the inserts in the front and rear aprons, side skirts and exterior mirror housings. The AMG twin-spoke forged wheels in titanium grey with a polished finish are equally expressive; alternatively, they are available in a 10-spoke design with a

polished titanium grey finish or a matt black finish, in all cases with 255/40 R 20 front tyres and 285/35 R 20 rear tyres and elaborate forged bolt covers. The dynamic design continues in the interior with carbon-fibre/black piano lacquer trim and an AMG performance steering wheel. Illuminated door sills with “AMG” lettering and exclusive AMG floor mats also form part of the special AMG Performance Studio range.

And if you’re aiming to drive the S 63 AMG and S 65 AMG at its top speed of 300 km/h, you may want to opt for the AMG Driver’s package, which includes driver training from professional instructors at the AMG Driving Academy.



The AMG ceramic high-performance compound brake with callipers in a special paint finish and “AMG Carbon Ceramic” lettering.

AMG Performance Studio equipment and appointments | Selection.



AMG trim in carbon fibre/black piano lacquer.



AMG Driver's Package, with a top speed of 300 km/h.



AMG carbon-fibre engine cover.



AMG door sill panels with "AMG" lettering, with white illumination.



AMG brake callipers, finished in red.



Exterior mirror of the AMG Exterior Carbon-Fibre package.



AMG Line.

Styling elements that further enhance your car's sportiness and exclusivity.



The AMG Line features powerful AMG bodystyling and dynamic light-alloy wheels in a choice of two designs. Sporty interior touches are provided by high-gloss black poplar wood trim, AMG sports pedals and a stylish wood/leather multifunction steering wheel.

Exterior

AMG 5-twin-spoke light-alloy wheels, painted in titanium grey with a high-sheen finish, with 245/45 R 19 front tyres and 275/40 R 19 rear tyres

AMG multi-spoke light-alloy wheels, painted in titanium grey with a high-sheen finish, with 245/40 R 20 front tyres and 275/35 R 20 rear tyres (optional)

AMG bodystyling (front and rear apron plus side sill panels with inserts painted in vehicle colour)

Chrome trim in rear apron (diesel models)

Perforated brake discs and brake callipers with "Mercedes-Benz" lettering

Two visible tailpipes (petrol models)

Interior

AMG velour floor mats with "AMG" lettering

AMG sports pedals in brushed stainless steel with rubber studs

Wood/leather multifunction steering wheel in high-gloss black poplar wood

High-gloss black poplar wood trim

AMG Line Plus.

Sportiness – taken to the limit.



In addition to the features of the AMG Line, the AMG Line Plus provides for an even more dynamic appearance. The carefully coordinated range of equipment comprises AMG multi-spoke light-alloy wheels, painted in high-gloss black and featuring a high-shine finish, AMG sports seats and an AMG sports steering wheel.



Exterior

AMG multi-spoke light-alloy wheels, painted in high-gloss black with a high-shine finish, with 245/40 R 20 front tyres and 275/35 R 20 rear tyres (optional)

Interior

AMG sports steering wheel

AMG sports seats in nappa leather or Exclusive nappa leather

Exclusive package.

The stylishly matched combination of high-quality features meets the highest standards for comfort, quality and design.

In addition to the characteristic diamond-design seating design along with the contrasting topstitching and piping for the seats, the generous use of nappa leather and wood trim also add to the interior's air of exclusivity. As do other details, such as the illuminated door sill panels with "Mercedes-Benz" lettering, the boot sill finished in stain-

less steel and the roof liner and sunblinds covered in stylish DINAMICA microfibre. The interior of the vehicle can be further stylishly individualised with the Exclusive trim package. The reverse sides of the front seat backrests are additionally faced in elegant wood, as are the door centre panels and the covers of the rear air vents. The

attractive designo high-gloss sunburst brown myrtle wood trim and designo metallised ash trim (options) complete the Exclusive package.



designo high-gloss sunburst brown myrtle wood trim.



Further wood trim elements in the door centre panels and on the backs of the front seats add to the high-class appeal of the rear.

Standard equipment | Selection.



LED High Performance headlamps.



Twin-spoke multifunction steering wheel in nappa leather with 12 pushbuttons.



THERMOTRONIC automatic climate control.



Electrically adjustable front seats.



DVD player.



Standard loudspeakers with Frontbass technology.

Optional extras | Selection.



LED Intelligent Light System.



Driving Assistance package Plus.



AIR-BALANCE package, including ionisation, air filtering and fragrance.



Head restraint cushions (integral part of electrically adjustable rear seats).



MAGIC BODY CONTROL.



Burmester® surround sound system.

Upholstery and trim.



The black colour scheme stands for masculine elegance. There is a choice of seats in black fabric, leather, nappa leather or Exclusive nappa leather. The roof liner is also in black, as are the armrest and the top section of the dashboard in ARTICO man-made leather. The door panels are lined with lavish, hand-sewn material. While the combination with the high-gloss dark brown eucalyptus shows off the aesthetic appeal of the interior to its fullest extent.



001



201



801 | 501 | 851 | 561



734



731



729



727



H06



H10



H21

black/black

001 Fabric

201 Leather

801 Nappa leather | 501 Exclusive nappa leather¹851 AMG nappa leather² | 561 AMG Exclusive nappa leather³

Trim

734 High-gloss dark brown eucalyptus wood

731 High-gloss brown burr walnut wood⁴729 High-gloss black poplar wood¹727 designo high-gloss sunburst brown myrtle wood^{1, 5}H06 designo metallised ash wood^{1, 5}H10 AMG carbon fibre/piano lacquer in black^{1, 5}H21 designo black piano lacquer^{1, 5}

¹ Optional extra. ² Only for S 63 AMG and S 63 AMG 4MATIC. ³ Optional extra available only for S 63 AMG and S 63 AMG 4MATIC. Standard for S 65 AMG. ⁴ Optional extra. Standard for S 600 and S 65 AMG. ⁵ Exclusive trim package included (Code 735).



The silk beige/espresso brown colour scheme gives the luxury saloon the character of a sophisticated lounge. The centre console, doors and instrument panel are covered in silk beige leather. The light beige nappa leather seats with their horizontal-fluting design, combined with high-gloss brown trim, looks inviting from the very start. The light-coloured roof liner opens up the space, promising boundless and relaxed journeys.



205

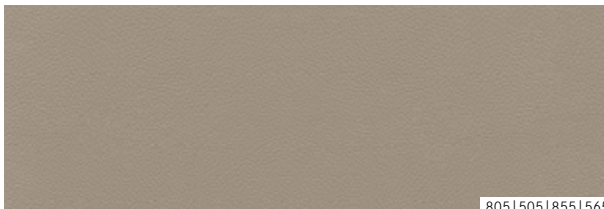

805|505|855|565



734



731



729



727



H10



H21

silk beige/espresso brown

205 Leather

805 Nappa leather | 505 Exclusive nappa leather¹

855 AMG nappa leather² | 565 AMG Exclusive nappa leather³

Trim

734 High-gloss dark brown eucalyptus wood

731 High-gloss brown burr walnut wood⁴

729 High-gloss black poplar wood¹

727 designo high-gloss sunburst brown myrtle wood^{1, 5}

H10 AMG carbon fibre/piano lacquer in black^{1, 5}

H21 designo black piano lacquer^{1, 5}

¹ Optional extra. ² Only for S 63 AMG and S 63 AMG 4MATIC. ³ Optional extra available only for S 63 AMG and S 63 AMG 4MATIC. Standard for S 65 AMG. ⁴ Optional extra. Standard for S 600 and S 65 AMG. ⁵ Exclusive trim package included in scope of delivery (Code 735).



From the very first glance, the crystal grey/seashell grey colour scheme is characterised by simple elegance. The light-coloured trim in designo metallised ash wood and the elaborate pattern on the nappa leather seats exude a sense of luxury. Even the steering wheel and centre console are in light-coloured leather, thereby stopping, along with the seats, the onslaught of heat and making the S-Class an optimal business saloon, even on days of high summer.



208



808|508|858|568



734



731



729



727



H06



H10



H21

crystal grey/seashell grey

208 Leather

808 Nappa leather | 508 Exclusive nappa leather¹

858 AMG nappa leather² | 568 AMG Exclusive nappa leather³

Trim

734 High-gloss dark brown eucalyptus wood

731 High-gloss brown burr walnut wood⁴

729 High-gloss black poplar wood¹

727 designo high-gloss sunburst brown myrtle wood^{1,5}

H06 designo metallised ash wood^{1,5}

H10 AMG carbon fibre/piano lacquer in black^{1,5}

H21 designo black piano lacquer^{1,5}

¹ Optional extra. ² Only for S 63 AMG and S 63 AMG 4MATIC. ³ Only for S 63 AMG, S 63 AMG 4MATIC and S 65 AMG. ⁴ Optional extra available only for S 63 AMG and S 63 AMG 4MATIC. Standard for S 65 AMG. ⁵ Exclusive trim package included in scope of delivery (Code 735).



The nut brown/black colour scheme is expressive and classy. The interior can be upholstered in leather, nappa leather or Exclusive nappa leather. The armrests of the centre console are optionally available in nappa leather, the wood trim here is in high-gloss dark brown eucalyptus, the roof liner in black.

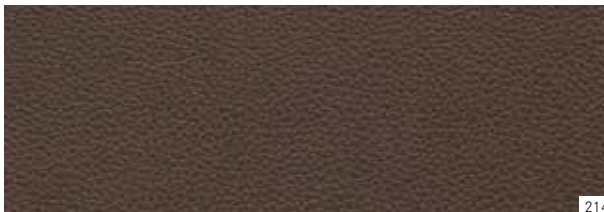

214



814|514|864|584



734



731



729



727



H10



H21

nut brown/black

214 Leather

814 Nappa leather | 514 Exclusive nappa leather¹

864 AMG nappa leather² | 584 AMG Exclusive nappa leather³

Trim

734 High-gloss dark brown eucalyptus wood

731 High-gloss brown burr walnut wood⁴

729 High-gloss black poplar wood¹

727 designo high-gloss sunburst brown myrtle wood^{1, 5}

H10 AMG carbon fibre/piano lacquer in black^{1, 5}

H21 designo black piano lacquer^{1, 5}

¹ Optional extra. ² Only for S 63 AMG and S 63 AMG 4MATIC. ³ Optional extra available only for S 63 AMG and S 63 AMG 4MATIC. Standard for S 65 AMG. ⁴ Optional extra. Standard for S 600 and S 65 AMG. ⁵ Exclusive trim package included in scope of delivery (Code 735).



This interior is the embodiment of modernity and expressiveness. The fabric roof liner, footwells and centre console come in black and contrast with the seats in porcelain Exclusive nappa leather with a diamond design, contrasting topstitching and piping. The same leather is used for the armrests on the centre console. High-gloss brown myrtle wood trim blends organically into the scheme.



815

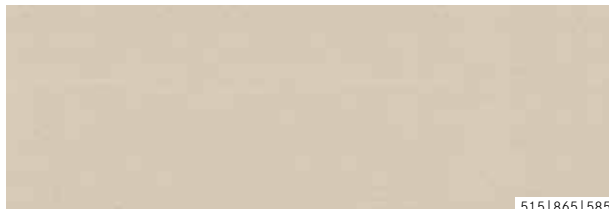

515|865|585



731



729



727



H06



H10



H21

porcelain/black

815 Nappa leather

515 Exclusive nappa leather¹865 AMG nappa leather² | 585 AMG Exclusive nappa leather³

Trim

731 High-gloss brown burr walnut wood⁴729 High-gloss black poplar wood¹727 designo high-gloss sunburst brown myrtle wood^{1,5}H06 designo metallised ash wood^{1,5}H10 AMG carbon fibre/piano lacquer^{1,5}H21 designo black piano lacquer^{1,5}

¹ Optional extra. ² Only for S 63 AMG and S 63 AMG 4MATIC. ³ Optional extra available only for S 63 AMG and S 63 AMG 4MATIC. Standard for S 65 AMG. ⁴ Optional extra. Standard for S 600 and S 65 AMG. ⁵ Exclusive trim package included in scope of delivery (Code 735).

designo.



The colouring of the designo Exclusive nappa leather upholstery emphasises the luxury positioning of the S-Class. Further designo appointments and information can be found at www.mercedes-benz.com/designo

For a maritime-style ambience, there are appointments in designo deep-sea blue/silk beige. The diamond-design seats with contrasting topstitching and piping are finished in nappa leather in deep-sea blue. The centre console, dashboard, doors and roof liner in silk beige form an aesthetic contrast to the dark leather. The trim in high-gloss sunburst brown brings to mind high-quality musical instruments.



502



727

deep-sea blue/silk beige^{1, 2}

502 designo Exclusive nappa leather

Trim

727 designo high-gloss sunburst brown myrtle wood³

¹ Exclusive trim package included in scope of delivery (Code 735).

² Not available for S 63 AMG.

³ Optional extra.

A unique interior finish in two variations: designo Exclusive semi-aniline leather in a choice of silk beige/satin red pearl or silk beige/titanium grey pearl.



silk beige/satin red pearl¹

975 designo Exclusive semi-aniline leather¹

995 designo AMG Exclusive nappa leather²

silk beige/titanium grey pearl¹

965 designo Exclusive semi-aniline leather¹

985 designo AMG Exclusive nappa leather²

Trim

731 High-gloss brown burr walnut wood

729 High-gloss black poplar wood

727 designo brown high-gloss sunburst myrtle wood

H10 AMG carbon fibre/black piano lacquer

H21 designo black piano lacquer

¹ Exclusive trim package included in scope of delivery (Code 735).

² Optional extra only for S 63 AMG, S 63 AMG 4MATIC and S 65 AMG.



2



5



6

1 Seats in finest **designo Exclusive semi-aniline leather in silk beige/satin red pearl** featuring an exclusive diamond design covering the entire seat centre section, the centre section of the centre console and the dashboard. Top section of dashboard, beltlines, centre section of centre console and armrests in the doors in satin red pearl nappa leather.

2 Rear seats in finest **designo Exclusive semi-aniline leather in silk beige/titanium grey pearl** featuring exclusive diamond design covering the entire seat centre section. Also on the centre console in conjunction with the First-Class suite. Centre armrest, beltlines and armrests in the doors in titanium grey pearl nappa leather.

3 Centre armrest in designo Exclusive semi-aniline leather in silk beige/satin red pearl featuring **exclusive diamond design**.

4 Optional stylish trim and steering wheel in **designo black piano lacquer**.

5 Elaborate Budapest piping, **upholstery buttons** and **designo badge**.

6 Armrest in designo **silk beige/titanium grey pearl** nappa leather.

Wheels.



9-spoke light-alloy wheel, painted in tremolite metallic with a high-sheen finish, with 245/55 R 17 tyre (option, Code 09R).



10-spoke light-alloy wheel, painted in vanadium silver, with 245/50 R 18 tyre (Code R41).



5-twin-spoke light-alloy wheel painted in himalayas grey with a high-sheen finish, with 245/45 R 19 front tyre and 275/40 R 18 tyre for the rear (Code R17).



Multi-spoke light-alloy wheel, painted in thulium silver, with 245/40 R 20 front tyre and 275/35 R 20 rear tyre (Code 13R).



Multi-spoke light-alloy wheel, painted in vanadium silver, with 245/55 R 17 tyre (Code 08R).



Multi-spoke light-alloy wheel, painted in vanadium silver, with 245/45 R 19 front tyre and 275/40 R 19 rear tyre (Code 11R).



7-triple-spoke light-alloy wheel, painted in thulium silver, with 245/45 R 19 front tyre and 275/40 R 19 rear tyre (Code 12R).



5-spoke light-alloy wheel, painted in thulium silver, with 245/40 R 20 front tyre and 275/35 R 20 rear tyre (ex-factory accessory wheel, Code 53R).

AMG wheels.



AMG 5-twin-spoke light-alloy wheel painted in titanium grey with a high-sheen finish, with 245/45 R 19 front tyre and 275/40 R 19 rear tyre (standard for AMG Line, Code 793).



AMG multi-spoke light-alloy wheel painted in titanium grey with a high-sheen finish, with 245/40 R 20 front tyre and 275/35 R 20 rear tyre (Code 769).



AMG 10-spoke forged wheel painted in titanium grey and polished, with 255/45 R 19 front tyre and 285/40 R 19 rear tyre (standard for S 63 and S 63 AMG 4MATIC, Code 788).



AMG 10-spoke forged wheel painted in matt black with high-sheen rim flange, with 255/40 R 20 front tyre and 285/35 R 20 rear tyre (only for S 63 AMG, S 63 AMG 4MATIC and S 65 AMG, Code 648).



AMG multi-spoke light-alloy wheel, painted in high-gloss black with a high-sheen finish, with 245/40 R 20 front tyre and 275/35 R 20 rear tyre (only in conjunction with AMG Line Plus, Code 789).



AMG 5-twin-spoke forged wheel, painted in titanium grey and polished, with 255/40 R 20 front tyre and 285/35 R 20 rear tyre (only for S 63 AMG, S 63 AMG 4MATIC and S 65 AMG, Code 753).



AMG 10-spoke forged wheel, painted in titanium grey and polished, with 255/40 R 20 front tyre and 285/35 R 20 rear tyre (only for S 63 AMG, S 63 AMG 4MATIC and S 65 AMG, Code 647).



AMG multi-spoke forged wheel, ceramic high-gloss polished finish, with 255/40 R 20 front tyre and 285/35 R 20 rear tyre (only for S 65 AMG, Code 696).

Genuine Accessories.

A Mercedes-Benz is more than just a car. It can be a travel companion, an office, a living space. And this diversity is reflected in the Mercedes-Benz Genuine Accessories range. → www.mercedes-benz-accessories.com

The Mercedes-Benz Genuine Accessories range for the S-Class is designed to make driving even more of an enriching experience. There is a choice of four interior fragrances for the optional AIR-BALANCE package, to conjure up a pleasant atmosphere inside the vehicle. Distinctive looks are provided by the striking rear spoiler and the 19-inch 5-spoke light-alloy wheels¹ with tyres

in size 245/45 R 19 at the front and 275/40 R 19 at the rear, in tremolite metallic with a high-sheen finish – designed to turn heads whether the vehicle is stationary or on the move. It's easy to transport everything you need for your active leisure time with our rack systems. The New Alustyle basic carrier bars, for instance, allow you to remain flexible when transporting sports equipment

and items of luggage. And you can combine the basic carrier bars with lots of different roof attachments, such as the “Comfort” combined ski and snowboard rack, for up to six pairs of skis or four snowboards. Its handy extension function facilitates loading and unloading.



The four fragrances in the AIR-BALANCE package sweeten the air in the S-Class.



5-spoke 19-inch alloy wheel with 245/45 R 19 front tyre and 275/40 R 19 tyre for the rear.



The practical New Alustyle “Comfort” ski and snowboard rack can carry up to six pairs of skis or four snowboards.

¹ Accessory wheels are supplied without tyres, wheel hub covers or wheel bolts; availability depends on engine and selected equipment; contact your Mercedes-Benz dealer for more information.





More than simply a star. A whole universe.

The range of **services from Mercedes-Benz**. Every Mercedes brings with it as a standard feature a reassuring feeling of safety on the road. But if you ever do need help, we're here for you around the clock. You can reach us from anywhere in Europe on the toll-free number 00800 1 777 7777¹ (or alternatively direct through Mercedes-Benz Contact²).

Ensuring that you can keep moving in the event of a technical breakdown, accident, vandalism or even misfuelling, the **Mercedes-Benz mobility package Mobilo³** is included as part of the standard specification. It covers the cost of local assistance, for example for towing your car away or for a replacement vehicle – and will do so in more than 40 countries across Europe for up to 30 years³. Furthermore, for the first four years following initial registration of the vehicle, Mobilo offers special mobility services in the case of workshop visits involving warranty or goodwill situations.

Avoid unexpected workshop costs⁴: a **Mercedes-Benz Service Contract** covers unforeseeable repairs, maintenance or wear parts, depending on the specific contract. Your local Mercedes-Benz dealer will be pleased to provide information about available Service Contracts and terms and conditions.

Mercedes-Benz Financial Services. Drive a Mercedes-Benz and remain flexible when it comes to payment: our attractive leasing and finance products make this possible – matched to your requirements and needs. We will also be happy to offer you a range of detailed insurance proposals. Just speak to your Mercedes-Benz dealer, who will be happy to provide information about our current range of financial services, terms and conditions.

¹ Alternatively: +49 69 95 30 72 77. Calls to a landline are chargeable. ² Calls from a mobile phone to a landline are chargeable. ³ When it expires, (four years after initial registration) Mobilo can be extended to up to 30 years from one service to the next by your authorised Mercedes-Benz service partner. ⁴ Mercedes-Benz service contract terms and conditions apply.

Enjoy the digital experience of Mercedes-Benz –

wherever you happen to be. Thanks to a range of offers optimised for smartphones and tablet computers, you can immerse yourself in the world of Mercedes-Benz even while on the move.

Insights into the full product range, a varied programme of entertainment and direct contact to a wide variety of services await you. Take an interactive tour with the **Interactive Owner's Manual**, for example, to get to know your dream car better. Experience the various functions in detail, take a close-up look at what's going on inside or explore the benefits of the particular model on your national Mercedes-Benz website.

With the **"Mercedes-Benz Guides"** app you can also explore the highlights of the various vehicles off-line. The app is available free of charge from the Apple® iTunes® Store (iOS) or the Google Play Store (Android).

Incidentally, our TV and magazine media are also available to watch and read digitally. Explore the whole brand world for yourself at www.mercedes-benz.com. Just click to take a look.

The **fascination of Mercedes-Benz**. A car whose name brings a gleam to the eyes of people all over the world, one that has featured in many a movie and been sung about in international hits, is surely far more than just a car. How did it come to this?

Discover just what has been moving the world for more than 125 years and take a fascinating journey through time as well as through the history of the automobile, in the **Mercedes-Benz Museum**. More than 1500 exhibits over a display area of 16500 square metres demonstrate the unique heritage and innovative power of the inventor of the automobile, among them one-off models such as the oldest Mercedes still in existence, built in 1902, or the legendary "Gullwing" cars. Welcome to a place of innovation: www.mercedes-benz-classic.com/museum

What would the history of Mercedes-Benz be like without **motorsport**? What would motorsport be without Mercedes-Benz? The first vehicle ever to win an automobile race was powered by a Daimler engine. The first Mercedes was a racing car. The Silver Arrows – a true legend. Out of this glorious past has grown an exciting present: the MERCEDES AMG PETRONAS Formula 1 team and the DTM Mercedes AMG C-Coupés fight it out weekend after weekend for points and victory.



Dimensions.

S-Class

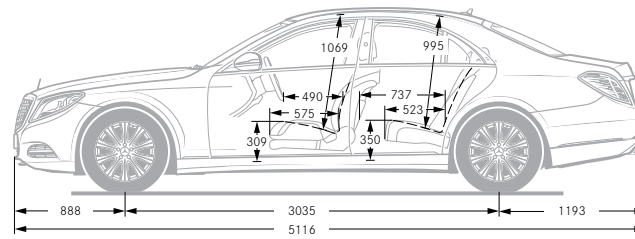
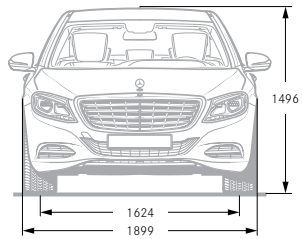

Long-wheelbase S-Class

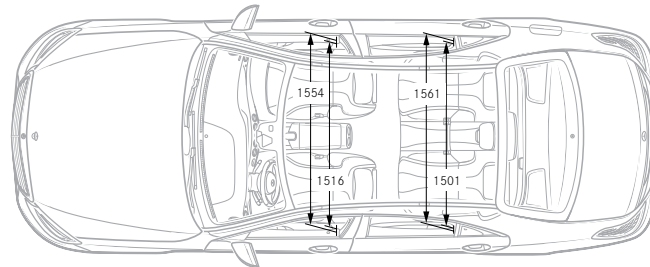
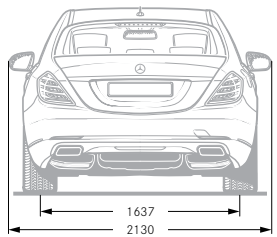
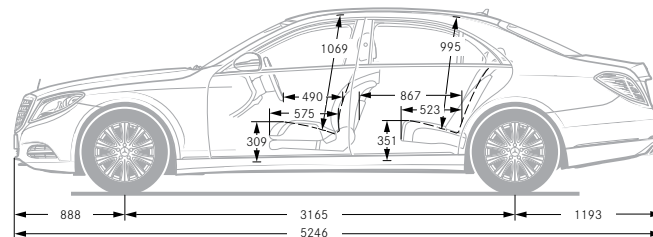
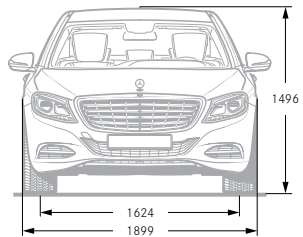

All dimensions in millimetres. The dimensions shown are mean values and apply to standard-specification, unladen vehicles.

Paintwork.

The paint system developed by Mercedes-Benz includes one of the best clear coats on the automotive market and is a key factor behind the car's excellent value retention. Its secret is the exceptionally thick molecular structure, which makes the metallic or non-metallic clear coat more resistant and produces a longer lasting and visibly more intensive shine.

Non-metallic paint

040 black

Metallic paints¹

183 magnetite black

197 obsidian black

474 peridot brown

775 iridium silver

792 palladium silver

890 cavansite blue

897 ruby black

988 diamond silver

998 anthracite blue

designo paintwork¹

799 designo diamond white bright

designo manufaktur paint finishes¹

033 designo mocha black metallic

044 designo allanite grey magno

049 designo cashmere white magno

Additional individual designo paint finishes are available from your Mercedes-Benz dealer.

¹ Option.

Technical data.

	Diesel engine		Petrol engines		
	S 350 BlueTEC	S 350 BlueTEC 4MATIC	S 500	S 500 4MATIC	S 600
Arrangement/number of cylinders	V6	V6	V8	V8	V12
Total displacement in cc	2987	2987	4663	4663	5980
Rated output ¹ in kW (hp) at rpm	190 (258)/3600	190 (258)/3600	335 (455)/5250-5500	335 (455)/5250-5500	390 (530)/4900-5300
Rated torque ¹ in Nm at rpm	620/1600-2400	620/1600-2400	700/1800-3500	700/1800-3500	830/1900-4000
Transmission	7G-TRONIC PLUS	7G-TRONIC PLUS	7G-TRONIC PLUS	7G-TRONIC PLUS	7G-TRONIC PLUS
Acceleration from 0-100 km/h (s) [long-wheelbase version]	6.8 [6.8]	6.8 [6.8]	4.8 [4.8]	4.8 [4.8]	- [4.6]
Top speed approx. in km/h [long-wheelbase version]	250 ² [250 ²]	250 ² [250 ²]	250 ² [250 ²]	250 ² [250 ²]	- [250 ²]
Tyre size	245/55 R 17	245/55 R 17	245/50 R 18	245/50 R 18	245/45 R 19 (front), 275/40 R 19 (rear)
Fuel consumption ³ in l/100 km					
Urban [long-wheelbase version]	7.3-7.0 [7.4-7.1]	7.7-7.4 [7.7-7.4]	12.8-12.1 [12.8-12.1]	13.3-12.8 [13.3-12.8]	- [16.4-16.2]
Extra-urban [long-wheelbase version]	5.1-4.7 [5.2-4.8]	5.6-5.1 [5.6-5.1]	7.1-6.4 [7.1-6.4]	7.5-6.9 [7.5-6.9]	- [8.4-8.2]
Combined [long-wheelbase version]	5.9-5.5 [6.0-5.6]	6.4-5.9 [6.4-5.9]	9.1-8.6 [9.1-8.6]	9.6-9.1 [9.6-9.1]	- [11.3-11.1]
Combined CO ₂ emissions ³ in g/km [long-wheelbase version]	155-146 [158-148]	168-156 [168-156]	213-199 [213-199]	225-211 [225-211]	- [264-259]
Emission class [long-wheelbase version] ⁴	Euro 6 [Euro 6]	Euro 6 [Euro 6]	Euro 6 [Euro 6]	Euro 6 [Euro 6]	- [Euro 6]
Efficiency class [long-wheelbase version]	A [A]	A [A]	D [D]	D [D]	- [F]
Tank capacity in l/incl. approx. reserve	70/8.0	70/8.0	80/8.0	80/8.0	80/8.0
Load capacity in l	510	510	530	530	500
Turning circle diameter in m [long-wheelbase version]	11.9 [12.3]	11.9 [12.3]	11.9 [12.3]	11.9 [12.3]	- [12.3]
Kerb weight ⁵ /perm. GVW in kg [long-wheelbase version]	1955/2655 [1975/2690]	2025/2715 [2045/2750]	1995/2695 [2015/2730]	2050/2715 [2070/2750]	- [2185/2740]
Perm. towing capacity (kg) braked/unbraked [long-wheelbase version]	2100/750 [2100/750]	2100/750 [2100/750]	2100/750 [2100/750]	2100/750 [2100/750]	- [-]

¹ Figures in accordance with Directive 80/1269/EEC in the currently applicable version. ² Electronically governed. ³ The figures shown were obtained in accordance with the prescribed measuring process (Directive [EC] 715/2007 in the currently applicable version). The figures are not based on an individual model and do not constitute part of the product offer; they are provided solely for purposes of comparison between the different vehicle models. ⁴ Data applicable within the European Union only.

Petrol engines

S 63 AMG	S 63 AMG 4MATIC	S 65 AMG
V8	V8	V12
5461	5461	5980
430 (585)/5500	430 (585)/5500	463 (630)/4800-5400
900/2250-3750	900/2250-3750	1000/2300-4300
AMG SPEEDSHIFT MCT 7-speed sports transmission	AMG SPEEDSHIFT MCT 7-speed sports transmission	AMG SPEEDSHIFT MCT 7-speed sports transmission
4.4 [-]	- [4.0]	- [4.3]
250 ² [-]	- [250 ²]	- [250 ²]
255/45 ZR 19 (front), 285/40 ZR 19 (rear)	255/45 ZR 19 (front), 285/40 ZR 19 (rear)	255/40 ZR 20 (front), 285/35 ZR 20 (rear)
13.8-13.8 [-]	- [14.1-14.1]	- [17.1-17.1]
7.9-7.9 [-]	- [8.1-8.1]	- [8.6-8.6]
10.1-10.1 [-]	- [10.3-10.3]	- [11.9-11.9]
237-237 [-]	- [242-242]	- [279-279]
Euro 6 [-]	- [Euro 6]	- [Euro 6]
E [-]	- [F]	- [F]
70/10.0	70/10.0	80/12.0
510	510	470
11.9 [-]	- [12.3]	- [12.3]
2045/2700 [-]	- [2070/2725]	- [2250/2750]
- [-]	- [-]	- [-]

Alternative drive systems

S 300 BlueTEC HYBRID	S 400 HYBRID
4/in-line	V6
2143	3498
150 (204) + 20 (27)/3800	225 (306) + 20 (27)/6500
500 + 250/1600-1800	370 + 250/3500-5250
7G-TRONIC PLUS	7G-TRONIC PLUS
7.6 [7.6]	6.8 [6.8]
240 [240]	250 ² [250 ²]
245/55 R 17	245/55 R 17
4.8-4.7 [4.8-4.7]	7.4-6.6 [7.4-6.6]
4.6-4.3 [4.6-4.3]	6.5-6.1 [6.5-6.1]
4.7-4.4 [4.7-4.4]	6.8-6.3 [6.8-6.3]
124-115 [124-115]	159-147 [159-147]
Euro 6 [Euro 6]	Euro 6 [Euro 6]
A+ [A+]	A [A]
70/8.0	70/8.0
510	510
11.9 [12.3]	11.9 [12.3]
2015/2715 [2035/2750]	1925/2595 [1945/2630]
- [-]	- [-]

⁹ Figures according to Directive 92/21/EC, version 95/48/EC (kerb weight with fuel tank 90% full, driver, 68 kg, and luggage, 7 kg) for standard-specification vehicles. Optional extras and accessories will generally increase this figure and reduce the payload capacity accordingly. Further technical data can be found at www.mercedes-benz.com

Non-metallic paint

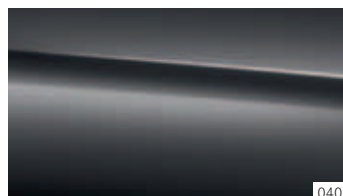

Metallic paints¹

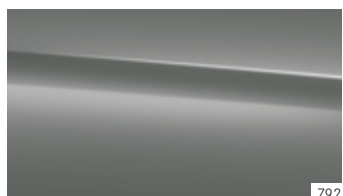
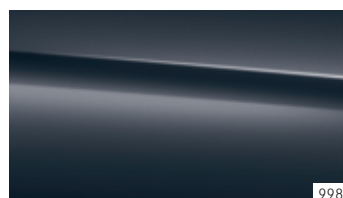
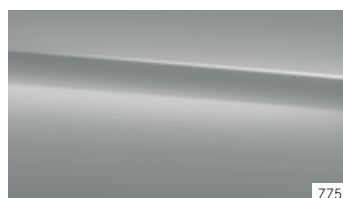
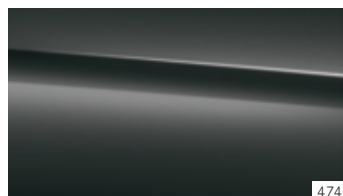
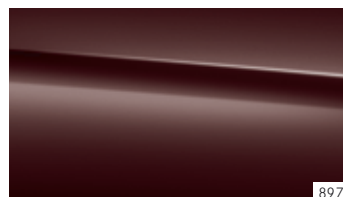
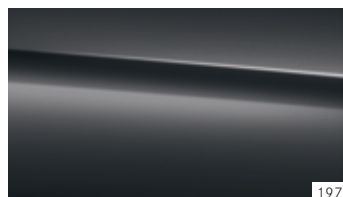
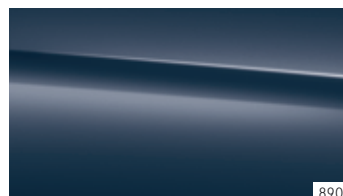

designo paintwork¹



designo manufaktur paint finishes¹

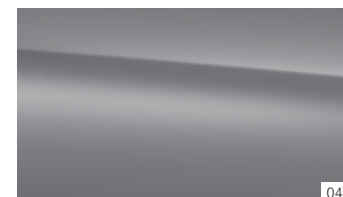
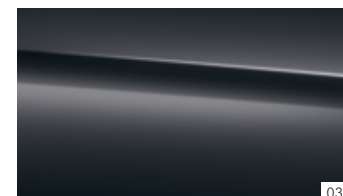

Take-back of end-of-life vehicles. At the end of its long life, you can return your S-Class to us for environment-friendly disposal in accordance with the European Union (EU) End-Of-Life Vehicle Directive. But that day lies a long way off.

A network of vehicle take-back depots and dismantlers has been established to make it as easy as possible for you to return your vehicle. You can leave it at any of these points free of charge and, by doing so, make an important contribution to completing the recycling process and conserving resources.

For further information about the recycling and disposal of end-of-life vehicles, and the take-back conditions, please visit the national Mercedes-Benz website.

Please note: changes may have been made to the product since this brochure went to press (27.01.2014). The manufacturer reserves the right to make changes to the design, form, colour and specification during the delivery period, provided these changes, while taking into account the interests of the vendor, can be deemed reasonable with respect to the purchaser. Where the vendor or the manufacturer uses symbols or numbers to describe an order or the subject of an order, no rights may be derived solely from these. The illustrations may show accessories and items of optional equipment which are not part of standard specification. Colours may differ slightly from those shown in the brochure, owing to the limitations of the printing process. This brochure is distributed internationally. It provides a general indication of the range of models, features, optional extras and/or colours available in various countries. Some of the models, features, optional extras and/or colours shown may not be available in your country or may only be available in combination with others. For current and more specific information in relation to the range of models, features, optional extras and/or colours available in your country, and their pricing, you should contact your nearest authorised Mercedes-Benz Passenger Car Dealer.

www.mercedes-benz.com