

The M-Class.



Mercedes-Benz



# The M-Class. For those in control.

Being in control means being able to rise not only to the challenges of the present but to those of the future, too. Representing the next stage in the development of the SUV, the M-Class embodies a strong sense of responsibility – a concept which we regard as an essential component of contemporary, superior mobility. This is why our vision was fixed firmly on the future throughout the development phase. We have been no less attentive to the other key aspects of the M-Class: advanced engine technology, breathtakingly attractive design, outstanding comfort and a benchmark safety concept. Together, these qualities make every trip a relaxing experience which can be enjoyed from the high driving position that gives you a commanding view, on or off the road.



## The featured models at a glance:

### 2 | Mercedes-Benz ML 250 BlueTEC 4MATIC

#### iridium silver metallic

5-twin-spoke light-alloy wheels, tobacco brown/marron/  
black leather, open-pore brown ash wood

### 10 | Mercedes-Benz ML 350 4MATIC

#### designo diamond white bright

AMG Exterior Sports package, Interior Sports package,  
AMG 5-twin-spoke light-alloy wheels, black leather, light  
longitudinal-grain aluminium

#### **Vision.**

20 | Moving innovation

#### **Drive system and chassis.**

22 | Diesel engines

23 | Petrol engines

24 | Transmissions

26 | Chassis and suspension

#### **Safety.**

30 | Integral safety concept

#### **Comfort.**

34 | Seats

35 | Climate control

36 | Load compartment management

38 | Multimedia systems

39 | Assistance systems

#### **AMG.**

40 | ML 63 AMG 4MATIC exterior

42 | ML 63 AMG 4MATIC interior

43 | ML 63 AMG 4MATIC Performance  
package and Performance Studio

#### **Equipment and appointments.**

44 | Standard equipment

45 | Optional extras

46 | AMG Exterior Sports package

48 | Interior Sports package

50 | designo

52 | Upholstery and trim

58 | Wheels

60 | Genuine accessories

#### **62 | Services.**

#### **Facts and colours.**

64 | Dimensions

64 | Paintwork

65 | Technical data

On: effortless superiority.  
Off: standstill.

We see it as one of the most convincing interpretations of effortless superiority: powerful, dynamic and expressive, but also efficient, refined and responsible. This is the definition of contemporary automobility. It ensures the highest degree of driving pleasure but also takes account of the need to ensure that driving remains a pleasure in the future, too. This is the definition of the M-Class.







Start: responsibility.  
Stop: excess.

As compelling and exciting as the M-Class is, it is also a model of environmental responsibility. An integral ensemble of BlueEFFICIENCY measures prevents waste. From the fuel-saving tyres to the ECO start/stop function to the standard-fit 7G-TRONIC PLUS automatic transmission, this vehicle proves that it is possible to enjoy the height of luxury while exercising moderation.







The image shows the interior of a Mercedes-Benz car, viewed from the driver's perspective. The car is parked at night, with a dark, open area visible through the windshield. Several streetlights are visible in the distance, casting a soft glow. The car's interior features brown leather seats and a steering wheel with the Mercedes-Benz logo. The text "Up: atmosphere. Down: monotony." is overlaid in the center of the image.

Up: atmosphere.  
Down: monotony.





>> Recognition value.  
<< Wind resistance value.

The M-Class is a vehicle with a strong identity. Its elegant, powerful forms make a clear statement of self-assurance while the visual V-shape styling of the rear apron and radiator area is complemented by many other design details to give the vehicle a particularly impressive presence. And these stunning lines are not just a delight for the eye: the M-Class also sets standards with its excellent aerodynamics.









↑ Breathing space.  
↓ Stress test.







The promise implicit in the exterior design of the M-Class is kept by the interior with its fine materials and painstaking workmanship. Standard-fit THERMATIC automatic climate control makes every journey a comfort trip and an optional web-enabled multimedia system allows you to turn your vehicle into an opera house or rock concert venue. The M-Class opens up a world of exciting new experiences – even without venturing off the road. → Page 35, 38



High: roadholding.  
Low: pulse rate.







Superiority needs a sound basis. Thanks to the combination of 4MATIC permanent all-wheel drive and 4ETS the M-Class has optimum traction characteristics and impressive pulling power, even in challenging terrain. High driving stability is ensured by the Electronic Stability Program ESP®. Add the optional ON&OFFROAD package along with the optional ACTIVE CURVE SYSTEM and you are home and dry in practically any terrain. The feeling that you are able to cope with just about any situation you might encounter is one you will soon get used to in the M-Class.

→ Page 26-29







+ Anticipation.  
– Apprehension.

Sitting higher means seeing further. But even though you are literally in a better position for an anticipative driving style, it's reassuring to know that numerous assistance systems are also keeping an eye out. If you start displaying signs of drowsiness or inattentiveness, for example, you will be reminded to take a break. You can also benefit from assistance when moving off on inclines. And during the journey the COLLISION PREVENTION ASSIST can prevent rear-end collisions, as its undivided attention is given to the traffic and the road ahead. The PRE-SAFE® system can recognise critical situations as soon as they start to develop and also initiate protective measures. Further optionally available active assistance systems can also monitor traffic conditions. The M-Class brings together more than 50 years of Mercedes-Benz safety research to bring you maximum peace of mind.

→ Page 30-33





Max.: pleasure.  
Min.: pressure.



## A welcome alternative to free-fall driving.

Feeling on top of the world is the natural reaction once your vehicle has made it up a steep incline. But then comes the question of how to get down again. Will you be able to keep it under control as you descend steep, off-road tracks? If the surface is unfavourable? If the gradient is as much as 100%? Might you not be in for a free-fall descent under these conditions?

There's no need to worry: in the M-Class you can enjoy the ride all the way down again, too. The patented Downhill Speed Regulation system can ensure a constant, pleasantly slow ground speed even when negotiating steep downhill

stretches and difficult terrain. The cruise control lever allows the speed to be adjusted at any time. So you can always count on a safe, gentle and relaxing descent – almost as if you were floating downhill.





# What makes a car a Mercedes?

Deep-rooted traditions: in our case, it is innovative traditions that run deep. We've gone along previously untravelled roads. Setting milestone after milestone. The first car with a crumple zone, the first ABS, the first diesel car. The first car. And whilst it's nice to look back, we'd much rather look forward.

**Mercedes me** – welcome to a world that revolves entirely around you. We focus on people. No more so than when we developed a new platform for you to keep in close contact with Mercedes-Benz. With services that are tailored to your needs. “connect me” connects the vehicle to your world of experience, to everything that is important to you. “move me” provides new mobility solutions. And “inspire me” gives you an exclusive insight into the future of mobility. Your gateway to a fascinating world: [www.mercedes.me](http://www.mercedes.me)



**Mercedes-Benz Intelligent Drive** – on the road to accident-free driving. We develop intelligent technologies that actively assist the driver and make driving tangibly easier. Valuable assistance systems are already available in your Mercedes-Benz: they help to maintain the distance to the vehicle in front automatically, brake the car when necessary and warn against imminent rear-end collisions or vehicles in the blind spot. The sensors of the driving assistance and safety systems are linked intelligently. Potential hazardous situations are detected earlier than ever and consequently avoided with increasing regularity. Discover the fascinating world of Mercedes-Benz Intelligent Drive at [www.mercedes-benz-intelligent-drive.com](http://www.mercedes-benz-intelligent-drive.com)

**BlueEFFICIENCY** – our vision of emission-free driving. Sustainability is a big word. And it's a prime consideration in absolutely everything we do. From minimising the environmental impact of our production operations to alternative drive concepts.

The aims are ambitious, as you can see. But what could be better than seeing these aims achieved whilst on a long drive in a Mercedes?

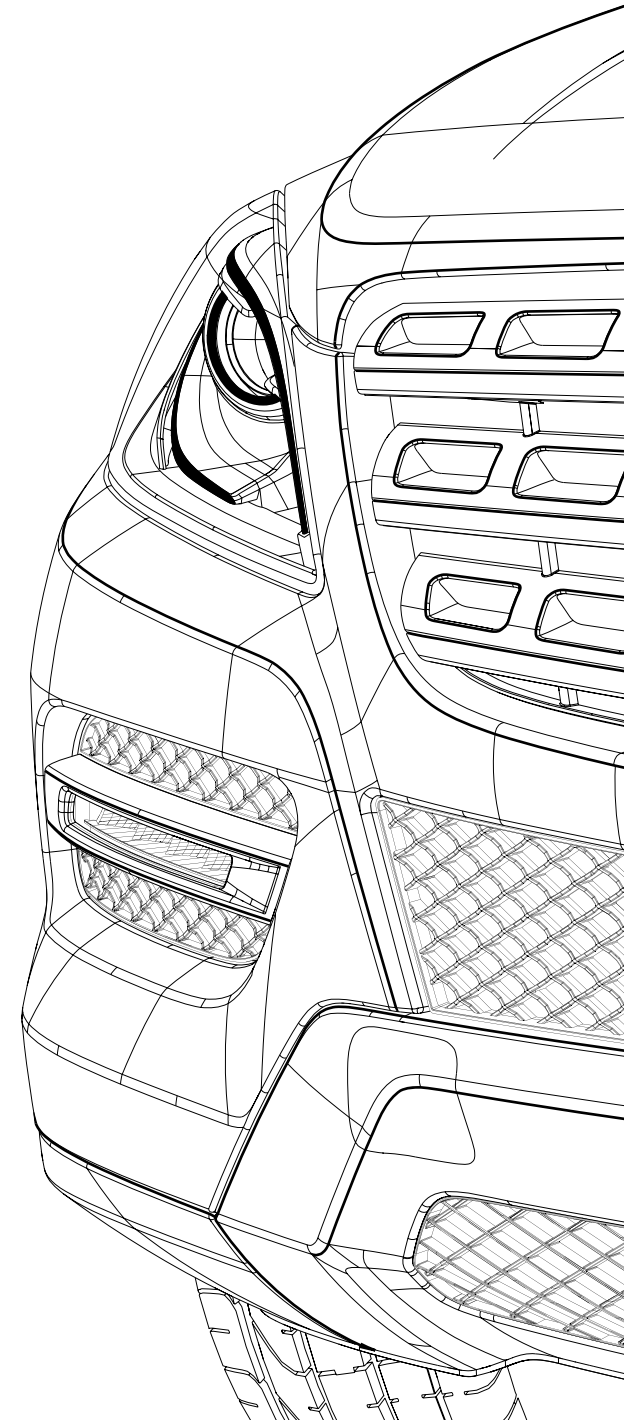



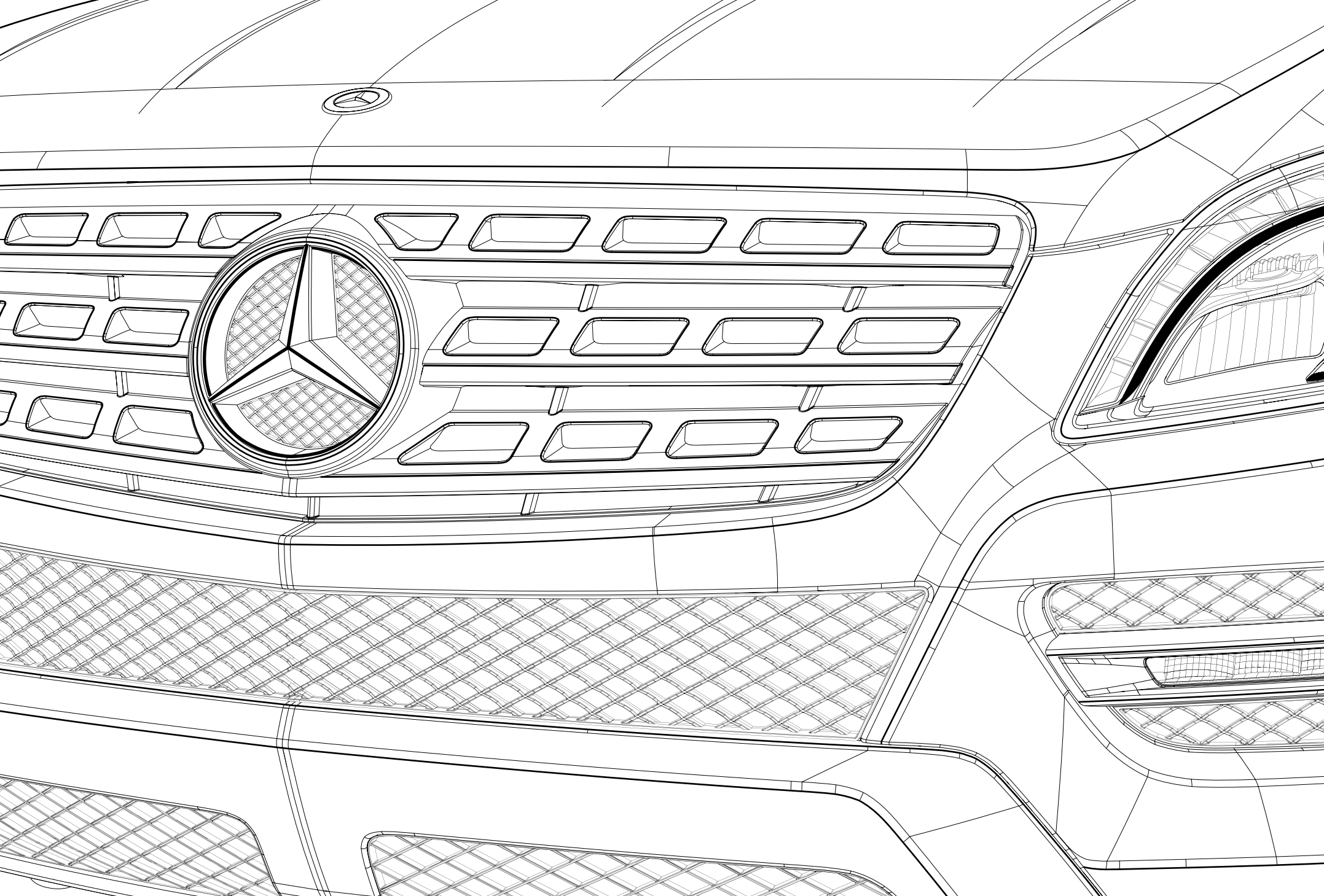

## Diesel engines.

Cleaner, more powerful and more economical: the M-Class features the latest BlueTEC diesel technology from Mercedes-Benz. Powerful and quiet, the engines also impress with their optimised emission and fuel-consumption figures, thanks to which they comply with the Euro 6 emission class.

**4-cylinder in-line engine.** The 4-cylinder diesel powerplant in the ML 250 BlueTEC 4MATIC delivers an impressive maximum torque of 500 Nm. At the same time, the diesel engine is conspicuously sparing on fuel, with combined consumption of 6.2–5.8 l/100 km, offers low CO<sub>2</sub> emissions of 163–154 g/km (combined), is quiet and – with 150 kW

(204 hp) – extremely powerful for its displacement class. This is made possible through a package of state-of-the-art technologies. The latest-generation common-rail diesel technology impresses with its injection pressures of up to 2000 bar, optimised combustion chambers and particularly fast and precise injectors. High ignition pressure and two-stage charging are responsible for the availability of high torque across the engine speed range while two Lanchester balancer shafts ensure the required smooth running.

figures bring home the benefits: compared with the nearest equivalent predecessor model, output is up to 23% higher while fuel consumption is reduced by up to 22%.

Both diesel engines are low on emissions thanks to the enhanced BlueTEC technology and therefore already meet the requirements of tomorrow's Euro 6 emission class. The BlueTEC catalytic converter technology cleans the exhaust gases, thereby making this diesel a more environmentally compatible drive system. In both models, the ECO start/stop function stops the engine when the car comes to a halt, while the optimised alternator management uses the engine's coasting phases as well as the braking process in order to recuperate kinetic energy. Meanwhile the radiator shutter reduces the aerodynamic drag when the engine requires only moderate cooling. But that is not all: measures such as tyres with low rolling resistance, intelligently controlled ancillaries and optimised aerodynamics help to boost the car's efficiency sustainably.

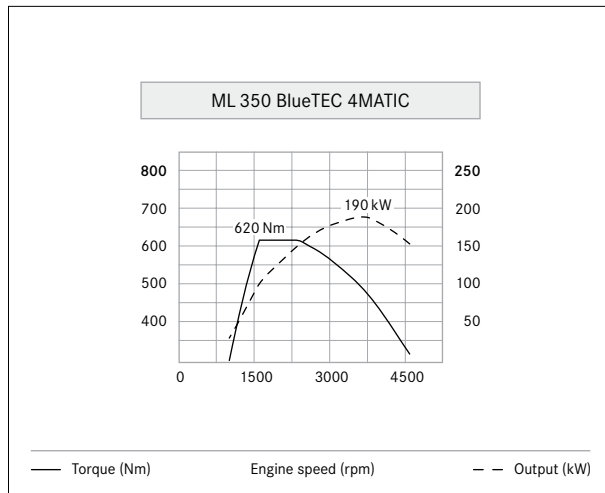

The ML 350 BlueTEC 4MATIC achieves its maximum torque of 620 Nm as early as between 1600 and 2400 rpm.

**V6 engine.** Uprated and optimised for reduced fuel consumption, the V6 diesel engine for the ML 350 BlueTEC 4MATIC features common-rail technology and develops 190 kW (258 hp). Precise, fast piezo injectors, a high injection pressure of up to 1600 bar, and an optimised turbo-charger combine to produce an immense peak torque of 620 Nm. This translates into effortlessly superior pulling power in all driving situations accompanied by a reduced environmental impact and lower fuel consumption. The



## Petrol engines.

Driving pleasure and efficiency can be reconciled by means of engine technologies which are impressively powerful but at the same time keep fuel consumption and CO<sub>2</sub> emissions low.

**V6 engine.** The BlueDIRECT petrol engines were developed with the aim of substantially reducing fuel consumption and emissions without compromising on dynamism and ride comfort. The result: state-of-the-art engine technology which offers effortlessly superior performance yet also takes a responsible approach to fuel consumption.

A 25% reduction in fuel consumption compared with the predecessor model and correspondingly lower CO<sub>2</sub> emissions are reconciled with enhanced dynamism in the ML 350 4MATIC. These benefits are due principally to the current generation of direct-injection petrol engines from Mercedes-Benz, which operates using spray-guided combustion and high-pressure injection via piezo injectors. The maximum output is 225 kW (306 hp), while the peak torque of 370 Nm is available between 3500 and 5250 rpm.

Factors contributing to the reduction in fuel consumption comprise the enhanced combustion process, the standard-fit ECO start/stop function, an optimised intake and exhaust system, regulated ancillaries, intelligent alternator management and the consistent use of lightweight construction principles. The excellent refinement of the V6 engine is particularly impressive.

**V8 engine.** In the ML 500 4MATIC an 8-cylinder petrol engine provides impressive performance. With 300 kW (408 hp) it delivers effortlessly superior power, putting maximum torque of 600 Nm on the road. The specially developed engine from the Mercedes-Benz BlueDIRECT engine family attains moderate consumption combined with low emissions – thanks to consistent lightweight design, downsizing to 4.7 litres displacement, direct injection

with particularly precise piezo injectors as well as trendsetting BlueEFFICIENCY technologies.

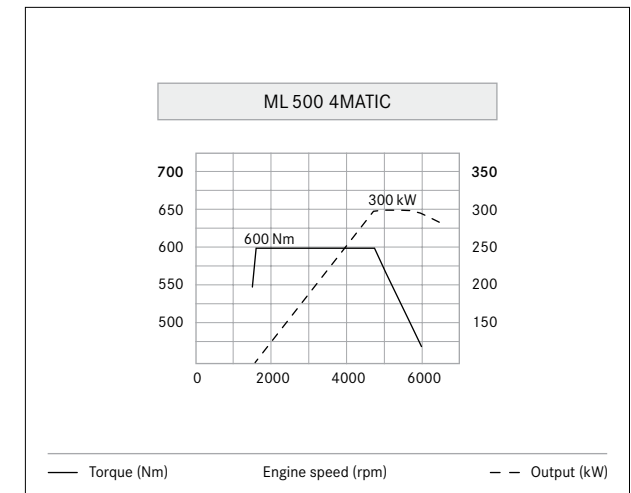

The ML 500 4MATIC achieves a powerful 600 Nm as early as at 1600 rpm, holding this torque steady until 4750 rpm.

## Transmissions.

Whether you favour an economical or a sporty driving style – the automatic transmission 7G-TRONIC PLUS is ideally matched to every engine and continuously adjusts to the current driving situation and driving style. What's more, it is intuitive and ergonomic to use.

**7G-TRONIC PLUS.** The M-Class is fitted as standard with the 7G-TRONIC PLUS 7-speed automatic transmission and the DIRECT SELECT lever on the steering column. Seven forward gears allow optimum revs at all times, thus reducing fuel consumption. In city traffic especially, the 7-speed automatic transmission brings about a further reduction in fuel consumption thanks to the ECO start/stop function which switches the engine off automatically when the vehicle comes to a halt. The electrohydraulic control unit, together with the engine and transmission software, results in particularly dynamic gear changes and very high shift quality. What's more, the 7G-TRONIC PLUS is characterised by its direct, immediate response to changes at the accelerator pedal.

**DIRECT SELECT.** Ergonomically designed and intuitive to operate, the DIRECT SELECT lever on the steering column allows the driver to set the automatic transmission positions P, N, R and D simply by giving it a light tap. The function commands are then transmitted wholly electronically. Additional steering-wheel gearshift paddles also facilitate manual pre-selection of the seven gears, so drivers can decide whether they want to change gear themselves using the steering-wheel shift paddles or whether they prefer this to be taken care of automatically.



Transmission control with the DIRECT SELECT lever on the steering wheel. The driver can intervene manually in the gear selection process by using the shift paddles on the steering wheel.



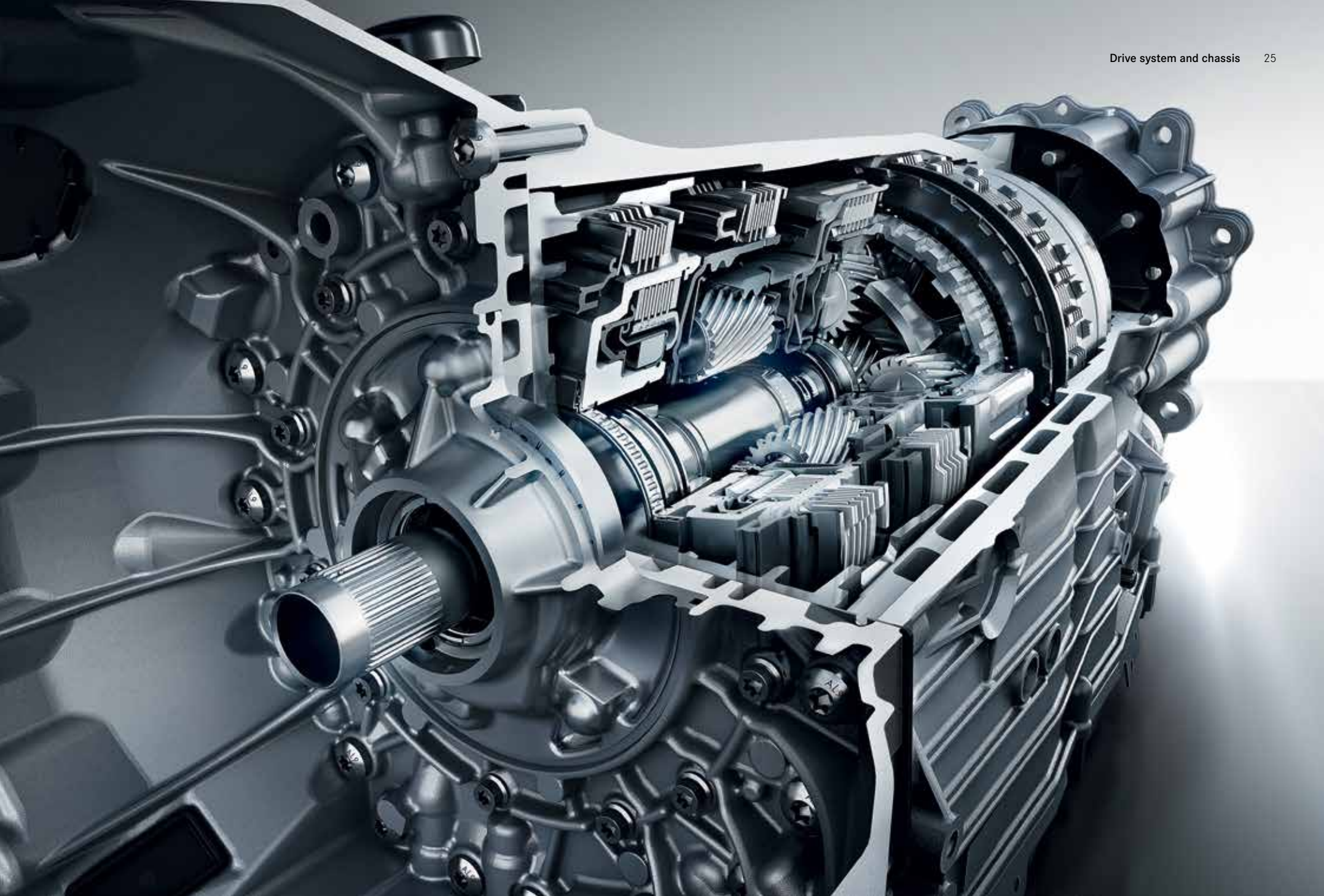

## Chassis & suspension.

The chassis and suspension of the M-Class impress with their fine driving dynamics and ride comfort. Working in concert with the 4MATIC permanent all-wheel drive, they enable optimum traction and make for enhanced driving stability both on poor roads and in off-road use.

**4MATIC all-wheel drive** (standard). The permanent all-wheel-drive system 4MATIC offers dynamic handling and enhanced stability both on- and off-road. As 4MATIC is always active, it is able to respond almost instantaneously in poor weather conditions such as rain, black ice or snow. It is assisted by the Electronic Stability Program ESP® and the electronic traction system 4ETS with integral ABS and ASR functions which provide additional support for the all-wheel drive. 4ETS enables controlled braking of spinning wheels and, as a consequence, directs the drive

torque to the wheels offering good traction, allowing plenty of power to be planted on the road when moving off and when accelerating, especially on poor road surfaces. 4MATIC makes conventional differential locks practically superfluous: the automatic braking pulses make it easier to move off on slippery ground and enhance stability during critical manoeuvres.

**Off-road driving mode with off-road button** (standard, not for ML 250 BlueTEC 4MATIC or ML 63 AMG). The off-road-driving mode supports the driver when using the vehicle off-road by adapting the settings for the engine output, automatic transmission, anti-lock braking system ABS, Electronic Stability Program ESP® and the electronic traction system 4ETS. This mode is activated by means of the off-road button in the centre console.

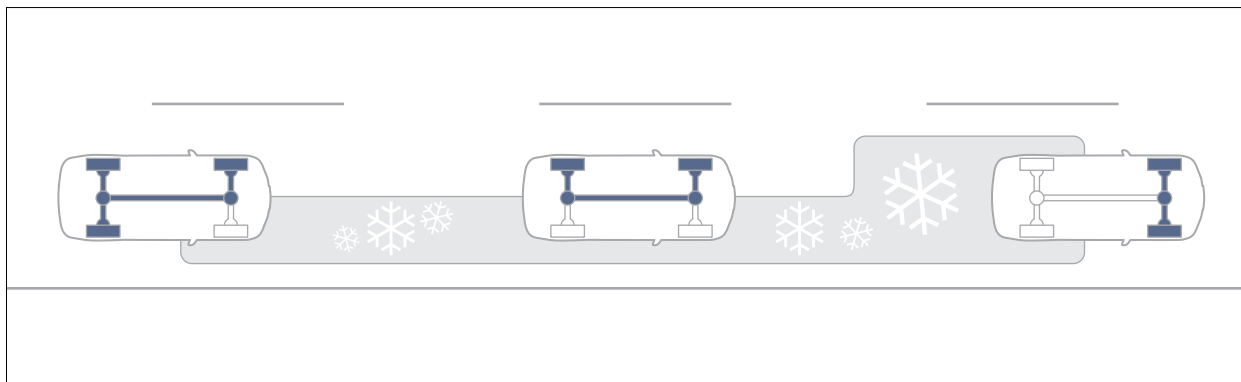

The electronic traction system 4ETS automatically transfers the drive torque to the wheels with the best traction.

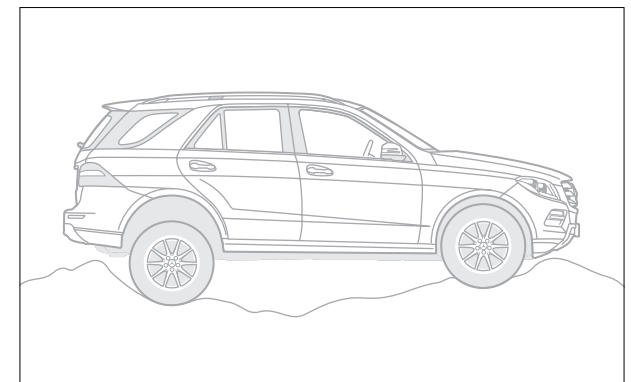

Effortlessly superior handling on the most varied of surfaces.



**Downhill Speed Regulation DSR** (standard). When the vehicle is negotiating steep downhill gradients, Downhill Speed Regulation allows the driver to set a speed of between 2 and 18 km/h which is maintained, within the bounds of physical possibility, through automatic control of the engine and transmission as well as the application of braking force. In this way DSR makes for more relaxed descents and enhances active safety during off-road driving.

**ON&OFFROAD package** (option in combination with the AIRMATIC package, not available for ML 63 AMG). Activated in an instant, the ON&OFFROAD package allows the driver to exercise even greater control over the handling of the M-Class, whether on or off the road. A rotary switch is used to select any of six pre-programmed driving modes with which the vehicle configuration can be adjusted to provide the best possible response to the current driving situation and road surface conditions. Elements and variables whose parameters are automatically adjusted in line with the selected driving mode include the engine, transmission, ESP®, 4ETS, ASR, steering, ground clearance, air suspension and damping. The selected driving mode

and animations of variables such as the gradient and angle of inclination are also shown in the COMAND display. In the highest off-road mode, AIRMATIC allows a ground clearance of 285 mm while the Sport mode sets it to 180 mm when running at high speeds in order to enhance agility and stability. The driver can choose between the following driving modes: AUTO (standard mode), Off-road 1 (sand and easy terrain), Off-road 2 (difficult terrain), Sport, Snow and Trailer. Furthermore, additional functions, such as a low-range ratio – for enhanced power, traction and handling safety in loose terrain – or manual mode for

the 7G-TRONIC PLUS automatic transmission can be engaged. Other components of the package include a centre differential lock as well as an underguard for the engine and reinforced underbody panelling for the entire vehicle which can provide enhanced protection during off-road use.



The COMAND display shows the driving mode as well as the gradient and angle of inclination.



A rotary switch in the centre console is used to set the current driving mode.

## Chassis & suspension.

Even in standard guise, the suspension of the M-Class with its selective damping system is extremely well prepared for a dynamic driving style yet delivers a remarkably comfortable ride at the same time.

**Direct-Steer system** (standard). The Direct-Steer system uses an increasingly direct steering ratio to reduce the steering effort required in the case of large steering angles – when parking or negotiating tight bends, for example. Conversely, straight-line running at high speeds is particularly stable. In this way, vehicle agility and steering comfort are increased by the precise steering response and good feedback. The outstanding handling of the M-Class is also evident in the small turning circle of just 11.80 metres. Power assistance is provided electromechanically and diminishes as the road speed increases. Another benefit of this system is that it helps save fuel as energy is only required for the actual steering movements.

**ACTIVE CURVE SYSTEM** (option for 6- and 8-cylinder models, standard for ML 63 AMG). The ACTIVE CURVE SYSTEM uses active stabilisers to reduce the roll angle of the vehicle when cornering, with the result that occupant comfort and driving dynamics are enhanced. This is evident in greater agility and driving enjoyment in the middle speed range on country roads as well as greater handling stability and improved straight-line running at high motorway speeds.

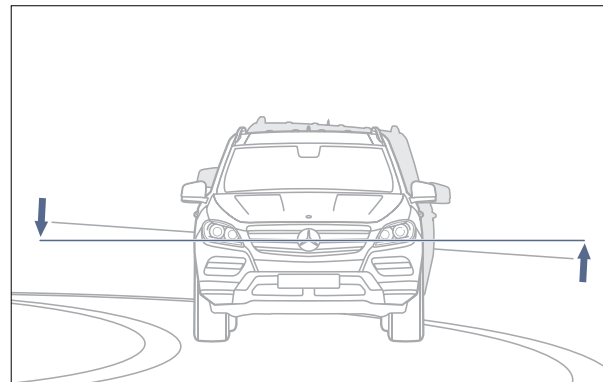

The ACTIVE CURVE SYSTEM reduces rolling movements to a minimum and increases ride comfort, agility and safety.

**Steel suspension with selective damping system** (standard). The suspension with a selective damping system combines agility with ride comfort, enhances the dynamic handling and comfort characteristics of the M-Class compared with the predecessor model, and also reduces noise and vibration. As the damping system adjusts automatically to the driving situation, the damping effect and stability are enhanced, especially on uneven ground. Featuring weight-optimised aluminium components, the double wishbone front suspension works in concert with the sophisticated four-link rear axle to ensure low road roar and tyre vibration characteristics, good driving dynamics and off-road capability.

**AIRMATIC package** (option for 4- and 6-cylinder models, standard for 8-cylinder model and ML 63 AMG). Thanks to the Adaptive Damping System ADS, the AIRMATIC air suspension adjusts precisely to the prevailing road and driving conditions by modifying the tuning in accordance with the road surface, driving style and load status. Compared with conventional steel suspension this reduces road roar and tyre vibration while enhancing handling safety in every driving situation. The integral all-round self-



levelling function ensures the vehicle body is maintained at a constant level regardless of the load status. A manual control allows the driver to switch between a comfort-oriented set-up or a sporty one. If necessary the vehicle also switches over to stiffer settings of its own accord. When running at high speed, the body is automatically lowered to a minimum ground clearance of 180 mm to optimise driving stability, aerodynamics and fuel consumption. Below 40 km/h the vehicle's body is raised to its normal level again. Off the beaten track the full air suspension with additional vehicle-level adjustment also boosts the off-road capability: a touch of a button is all it takes to increase the ground clearance to as much as 255 mm (or 285 mm in conjunction with the ON&OFFROAD package).



AIRMATIC air suspension enhances safety and reduces road roar and tyre vibration with the Adaptive Damping System ADS and integral all-round self-levelling.

## Integral safety concept.

We are driven by our vision of accident-free motoring. With our integral safety concept we are coming closer to achieving this goal – this is a holistic approach which can increase safety in every situation.

As the inventor of the automobile we feel that we have a special responsibility for road safety. This is why we are the first car manufacturer to have developed an integral safety concept which seamlessly blends measures to enhance active and passive safety. The holistic approach is subdivided into four phases and offers safety solutions for every situation. It includes systems for safe driving which help to avoid risks by warning you and coming to your aid in good time. Our unique PRE-SAFE® system is activated in the event of danger and activates anticipatory measures for occupant protection. If a collision should occur despite these precautionary measures further technologies ensure protection as needed. We have also borne in mind the time immediately following an accident and developed solutions which can help prevent worse and facilitate rapid help.

A selection of these technologies for the “Safe driving”, “In the event of danger”, “In an accident” and “After an accident” phases is presented on the following pages.

**Safe driving: ATTENTION ASSIST** (standard). This innovative drowsiness-detection system is especially useful on long trips. At speeds of between 80 and 180 km/h, ATTENTION ASSIST warns the driver as soon as it detects signs of increasing inattention or drowsiness. Sensors analyse driving behaviour and can detect deviations from a previously determined, individual driver profile.



If signs of increased driver drowsiness are detected, ATTENTION ASSIST advises taking a break.

**Safe driving: Intelligent Light System** (option). The system includes bi-xenon headlamps with five functions: country mode, motorway mode, enhanced fog light function, cornering light function and active light function. Adaptive Highbeam Assist, which can be ordered additionally as an option, selects the optimum low-beam headlamp range. The headlamps are dimmed as soon as vehicles driving ahead/oncoming vehicles with their lights on are detected. The standard-fit LED daytime running lamps integrated in the front bumper enhance



Adaptive Highbeam Assist always provides the best possible headlamp range automatically, thereby improving visibility for the driver.



perceptual safety during the daytime. On request the M-Class with the ON&OFFROAD package and Intelligent Light System can also be equipped with a special off-road light. Developed for use off the beaten track, the system provides particularly broad and bright illumination of the route.

**Safe driving: Night View Assist Plus** (option). The COMAND display highlights the entire area normally covered by main beam, as recorded by the Night View



To ensure better driver awareness, Night View Assist Plus highlights pedestrians on the display.

Assist system's infrared camera, in the form of a greyscale image. This makes it easier for drivers to get their bearings in situations where main beam cannot be switched on and allows them to react quicker to people detected on or next to the road. What's more, pedestrians detected by the system are designated on the display by the special pedestrian recognition function for enhanced driver awareness.

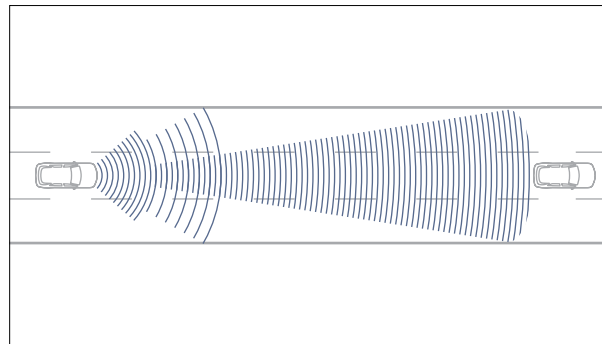

DISTRONIC PLUS adaptive cruise control can brake the car to a standstill then accelerate it again, for example when driving in a queue of traffic.

**Safe driving: Driving Assistance package Plus** (option).

The package comprises several intelligent individual technologies: with a subtle vibration on the steering wheel the Active Lane Keeping Assist warns the driver as soon as he or she leaves the recognised, marked lane unintentionally. If the driver fails to react, a lane-correcting brake actuation can occur. Active Blind Spot Assist ensures increased safety when changing lanes. Two radar sensors observe the area which the driver cannot see well in the exterior mirrors – the “blind spot”. During a lane change with an actuated indicator, if the assistance system detects a vehicle in the danger zone, an acoustic signal warns against the risk of a possible collision. If the driver does not react to this, the brakes are applied selectively on one side, which can prevent a potential collision. DISTRONIC PLUS adaptive cruise control uses radar to help the driver maintain a preset distance between the car and the vehicle in front, making the driver's job easier in moving as well as stop-and-go traffic. The Driving Assistance package Plus is rounded off with Brake Assist BAS PLUS and the PRE-SAFE® Brake – for a reassuring sense of safety on every trip.

**In the event of danger: COLLISION PREVENTION ASSIST** (standard). At speeds of more than 7 km/h the system is able to detect when distances between the vehicle in which it is fitted and those in front or stationary obstacles are too short. If a hazard is detected the driver is given both visual and acoustic warnings. During simultaneous braking the standard-fit Adaptive Brake Assist can place at the driver's disposal precisely the amount of braking power which is required to prevent an impending collision wherever possible.

**In the event of danger: PRE-SAFE® system** (standard). The PRE-SAFE® anticipatory occupant protection system

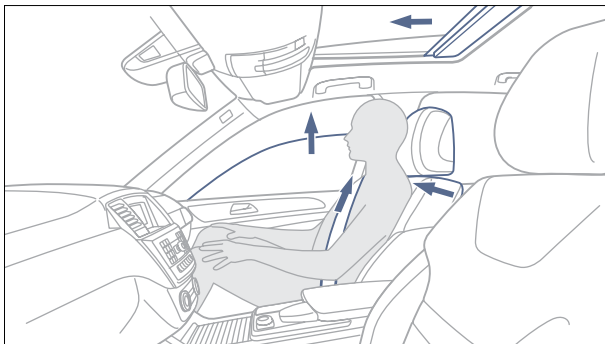

PRE-SAFE® can recognise critical driving situations and initiate preventive measures to protect the occupants.

can detect critical driving situations as they start to arise and initiate preventive measures. The front seat belts can be reversibly tensioned, while open side windows or the optional sliding sunroof can be closed, depending on the driving situation and the car's specification. These measures allow the seat belts and airbags to be deployed as effectively as possible should an accident occur. What's more, the optionally available Memory function can move the front passenger seat into a favourable position. If the accident is avoided, the seat belts are released again, while the other components can be adjusted to the desired position. The system is then ready for action again straightaway.

**In an accident: pedestrian protection with active bonnet** (standard). The active bonnet system can reduce the risk of injury to pedestrians and cyclists in a collision. If sensors in the front bumper detect an impact, the bonnet can be raised by pyrotechnic means. The resulting increase in space between the comparatively soft bonnet and the hard components in the engine compartment reduces the severity of the impact and can therefore diminish the risk of severe injuries.

**In an accident: restraint systems** (standard). Three-point seat belts, belt tensioners, belt force limiters and airbags are optimally coordinated with each other in Mercedes-Benz vehicles, so as to keep injuries to a minimum wherever possible. By way of example, the occupants in the M-Class are protected by seven airbags which can help prevent or reduce the risk of injury in a collision. For the passengers' protection two adaptive front airbags are fitted, and depending on the severity of the accident they are triggered in two stages. In addition, the M-Class has sidebags (combined thorax/pelvisbags) for the driver and front passenger in the front seat backrests, plus two generously sized windowbags over both rows of seats. The kneebag can further reduce the load on the driver during an accident. As an option sidebags are available in the rear. If the crash sensors detect an accident, the seat belts are tensioned in an instant by pyrotechnic means in order to keep the passengers securely in their seats. In addition, the belt force limiter relaxes the belt in accordance with the prevailing situation, so as not to place too much of a strain on the thorax of the occupants. Four of the seats in the M-Class have a belt tensioner and a belt force limiter, meaning that Mercedes-Benz is also leading the way in this area of safety.



**After an accident: Mercedes-Benz emergency call system<sup>1</sup>** (part of COMAND Online). This system can make an emergency call automatically using a mobile phone which is on standby in the vehicle as soon as the restraint system detects an accident. At the same time, the GPS position data and other data about the vehicle are transmitted to the Mercedes-Benz emergency call centre, after which a voice connection is established. The emergency call system can also be triggered by pressing the SOS button.

**Measures after an accident.** In order to reduce consequential damage and, where necessary, to support the rescue of the occupants, Mercedes-Benz has developed further measures. These include automatic engine cut-off and activation of the hazard warning lamps and interior emergency illumination. The central locking also unlocks automatically and makes it easier to open the doors after an impact. Mercedes-Benz also provides multilingual rescue guidelines which emergency services can download online worldwide at [www.mercedes-benz.de/rettungsleitfaden](http://www.mercedes-benz.de/rettungsleitfaden). As you can see, at Mercedes-Benz consideration has been given to safety in every situation.

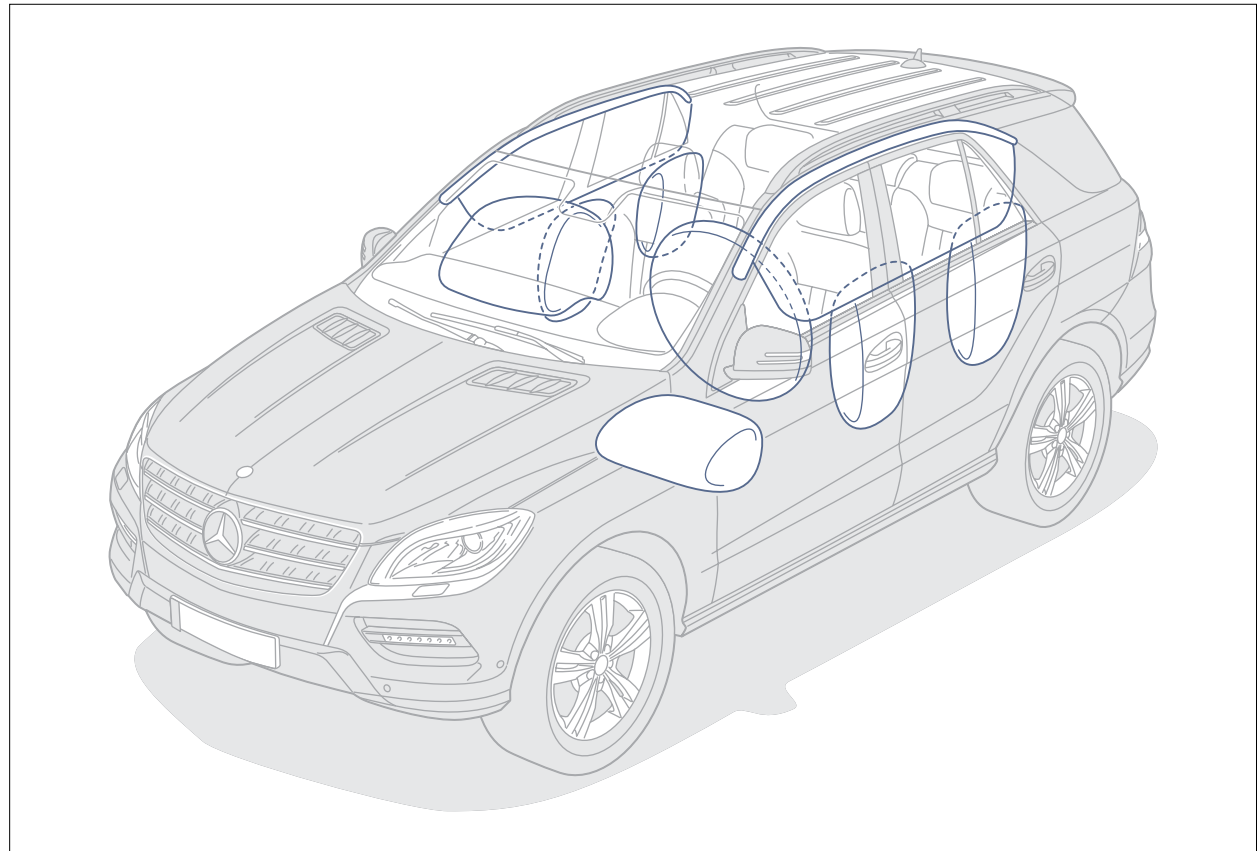

Standard equipment includes windowbags over both rows of seats, airbags and sidebags for the front-seat occupants as well as a driver kneebag.

<sup>1</sup> Available over the entire operating life of the vehicle in 19 European countries.

## Seats.

The seats and interior of the M-Class meet the high standards set by discerning customers and are designed to provide impressive long-distance comfort.



**Fully power-adjustable seats** (standard). The high-quality seating in the M-Class offers both front and rear occupants a high level of comfort on long journeys, optimum ergonomics and generous amounts of legroom and shoulder room. Both front seats are fully power-adjustable as standard and are also provided with intuitive seat adjustment switches which are well arranged in the door panels.

As an option front climatized seats are also available, as is seat heating for both rows of seats. The climatized seats comprise three-stage seat heating and active multistage ventilation for cooling the seat surfaces. What's more, the seats impress with their carefully selected materials and painstaking workmanship, thus making a visible contribution to the interior's high-class appeal.

**Multicontour seats, including luxury head restraints** (option). Those wishing to enjoy an especially comfortable ride can opt for multicontour seats with a massage function and luxury head restraints, which make every journey a more relaxed one for the driver and front passenger.



## Climate control.

A pleasant interior climate with numerous variable-control options plays a big part in enhancing driver-fitness safety.

**THERMATIC** (standard). The automatic climate control can automatically control the temperature separately for the driver and front passenger by means of sensors as well as automatically controlling the ventilation. The air distribution can be individually controlled for the rear passengers. Further standard features include air recirculation, a cooled glove compartment and a particulate matter activated charcoal filter which reduces dust, soot and pollen as well as pollutants and odours in the air.

**THERMOTRONIC** (option). This automatic climate control system allows individual interior climate settings for the driver, front passenger and rear passengers. There is a separate control unit specially for the rear. Additional air outlets in the B-pillars, two pivoting air vents in the centre console and a booster blower ensure the ideal temperature in the rear. There is a choice of three climate modes in automatic mode: DIFFUSE, MEDIUM or FOCUS. Automatic air recirculation ensures good air quality inside the car.

**Heated multifunction steering wheel** (option). At the touch of a button the rim of the steering wheel is heated to a temperature of 35°C in order to provide a pleasant grip area even during cold weather. Like other comfort features, such as the optional temperature-controlled front cup holders, which can be set to maintain any temperature between 8°C and 55°C, the heated steering wheel creates a pleasant sense of well-being, whatever the season.



The THERMOTRONIC automatic climate control system operates extremely effectively without producing draughts. It is easy to use, fast to respond and quiet.



The temperature-controlled cup holders are suitable for hot and cold drinks and also provide protection against spillage.

## Load compartment management.

Up to five people can enjoy the spaciousness provided by the M-Class, with the rear bench seat offering not only a large amount of kneeroom but also plenty of interior height and particularly generous shoulder and elbow room.

The interior of the M-Class is so spacious that three child seats can be secured next to each other without any difficulty. What's more, the outer rear seats are equipped with ISOFIX child seat anchorage points as standard. The high, upright seating position means that all the occupants can enjoy a good view. Rear passengers can also adjust the angle of the backrests independently. Despite all this passenger space, the load compartment still offers a capacity of 690 l (measured up to the top edge of the rear backrest) with five occupants on board (1025 l if loaded to roof level).

Making full use of the space provided by the M-Class is quick and easy. It takes just a few adjustments to fold the 1/3 : 2/3 split backrests and cushions of the second row forwards to create a flat load area. With the rear seats folded, the tailgate gives you access to a load area with a capacity of 2010 l and an almost flat floor. This figure also includes a 90 l stowage compartment under the load compartment floor. With a maximum load compartment floor length of some 1.83 m, the M-Class certainly won't cramp your style and even opens up new possibilities for transporting items.

Four load-securing rings on the load compartment floor, four bag hooks at beltline level and two clothes hooks on the tailgate facilitate flexible use of the load compartment. Optimum accessibility is ensured by a tailgate whose headroom of 1.99 m (1.98 m in the case of the ML 250 BlueTEC) when open allows excellent freedom of movement for loading. The load sill has a stainless-steel cover to prevent the bumper and load compartment from being scratched or damaged during loading and unloading.



The load compartment of the M-Class can be extended as required.



Space for three people and a loading length of 1.83 m behind driver's seat.



The M-Class has one of the largest load compartments in its segment.



**EASY-PACK load-securing kit** (option). The EASY-PACK load-securing kit provides a practical way of securing the load and offers greater protection against damage during loading and unloading. The system consists of two load compartment rails, which are secured to the load compartment floor on the left and right sides and are used to hold load-securing elements. The telescopic bar included in the package allows the load compartment to be divided flexibly into different zones or bulky items to be secured. Bulky or round items can be attached to the load compartment sides using the retractable load-restraining belt.



The EASY-PACK load-securing kit makes loading convenient and easy.

**EASY-PACK tailgate** (option). The EASY-PACK tailgate which can be opened and closed automatically allows the load compartment to be loaded and unloaded conveniently. The tailgate is opened and closed using either a switch on the driver's door, the pushbutton on the inside of the tailgate, the buttons of the remote control or the exterior tailgate handle. The motor is equipped with an obstruction sensor which triggers an automatic reversal function. It is possible to restrict the opening angle to any chosen point whenever required. Manual opening and closing is possible by using the release handle on the tailgate.



Out of sight: lockable laptop compartment under load compartment floor.

**Optional extras for the load compartment** (option). The load compartment cover makes for a tidy appearance while providing protection from prying eyes. The optional load compartment cover including a safety net behind the second row of seats can also protect the occupants from unsecured objects in the load compartment. The optional through-loading feature above the rear armrest is particularly practical when transporting skis.



Rear armrest with through-loading feature.

## Multimedia systems.

The M-Class can be optionally equipped with the full range of entertainment and navigation systems, from the COMAND Online multimedia system and the BeoSound AMG high-end sound system from Bang & Olufsen to the Rear Seat Entertainment System for the rear passengers.

**COMAND Online** (option). This system is a combination of audio and navigation systems as well as telephone and internet functions. Excellent entertainment comes courtesy of a DVD player with Music Register, 10 GB hard disc and remote control. Any web-enabled mobile phone allows access to mobile services from Mercedes-Benz. USB and Bluetooth® interfaces are standard, as is an SD memory card slot. LINGUATRONIC allows you to operate the system by voice entry. SPLITVIEW technology, which can be ordered additionally as an option, allows the driver and front passenger to view different content at the same time on the COMAND display.



SPLITVIEW shows the driver and front passenger different content at the same time.

**Live Traffic Information**<sup>1</sup> (part of COMAND Online). This service allows the reception of up-to-date and precise traffic information in real time for optimised dynamic route guidance and a more accurate estimated time of arrival. The data are transferred via a communications module that uses an integral SIM card with data roaming to provide the connection to the internet.

**Rear Seat Entertainment System** (option). The Rear Seat Entertainment System comprises a DVD player, two TFT colour displays with a 20.3 cm diagonal on the front power head restraints, two sets of wireless headphones and remote control, allowing the rear passengers to watch films or connect a games console during the journey. Both displays can be used independently of one another. Thanks to the optionally available TV receiver passengers in the M-Class can even watch broadcast TV programmes.

**Bang & Olufsen BeoSound AMG** (option). With the Bang & Olufsen BeoSound AMG high-end sound system from the Danish audio specialist you can actually see as well as hear the perfect acoustics. For the 14 high-performance loudspeakers with a total power of 1200 watts blend superb technology with an exclusive design. The sub-woofer is located on the left in the side wall behind the 2<sup>nd</sup> seat row, the mid-range speakers and woofers in the front and rear doors. It sounds as if you were in a concert hall rather than travelling in a car.

**Becker® MAP PILOT** (option). The Becker® MAP PILOT has everything you look for in a fully featured, advanced navigation system. Fully integral, it can be operated via the Controller and also via the display of the Audio 20 CD. What's more, it offers further scope for individualisation by downloading current map data and additional functions. A cradle for the control unit in the glove compartment allows the system to be used flexibly and to be removed from the vehicle.

<sup>1</sup> 3 years of free use, available in 12 countries.



## Assistance systems.

Optional assistance systems provide the driver with additional support in various driving situations and further enhance the feeling of comfort and security which the M-Class inspires.

### Active Parking Assist, including PARKTRONIC (option).

This system enables the car to enter and exit parking spaces automatically at the press of a button – the driver only has to operate the accelerator, gearshift and brake. The system looks for a suitable parking space and manoeuvres into it as soon as the driver stops, confirms the suggestion and engages reverse gear. PARKTRONIC includes a total of ten ultrasound sensors which measure the distance to the vehicle at the front and back during the automatic parking procedure. A control unit processes the sensor signals and calculates the optimum path into the parking space.

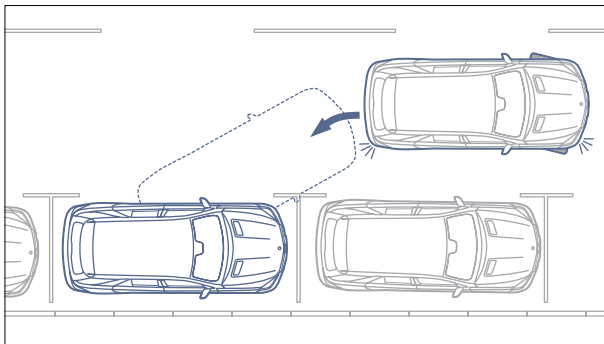

The system completes the automatic parking procedure in a maximum of five moves.

**Parking package with 360° camera (option).** The Parking package adds a 360° camera to Active Parking Assist and PARKTRONIC. The system's four close-range cameras produce a 360° image of the vehicle and its surroundings from a bird's-eye view and show it on the display of the centre console. The result: a better view and thus greater handling safety off-road when manoeuvring and parking. Moreover, acoustic and visual warnings of obstacles are provided. The individual camera images can also be selected and displayed separately.



The 360° camera produces an image of the M-Class and its immediate surroundings from a bird's-eye view.

### Speed Limit Assist (part of the COMAND Online option).

A windscreen-mounted camera that permanently scans the car's surroundings is able to recognise signed speed limits and indicate the detected maximum speed in the display. The driver can therefore check the prevailing speed limit at any time. This added convenience is of particular benefit on routes with variable speed limits or roadworks. In addition, Speed Limit Assist compares the signposted speed limits with the data from the navigation system.



The information from Speed Limit Assist is shown both in the instrument cluster and in the COMAND Online central display.

## ML 63 AMG 4MATIC exterior.

AMG – around the world these three letters are recognised as standing for cutting-edge technology, exclusivity and outstanding driving dynamics. Before you even get into the ML 63 AMG its unique charisma makes it clear that this model is a powerful symbol of compelling dynamic excellence. → [www.mercedes-amg.com](http://www.mercedes-amg.com)



An exceptional character and powerful dynamics are combined in an extremely versatile vehicle: the ML 63 AMG.

The very first encounter with the ML 63 AMG is an electrifying experience: even when stationary, it conveys the characteristic sense of AMG power and performance through the energy and expressiveness of its charisma. This model combines the self-assured presence of a premium SUV with the design of a sports car: one glance is all it takes to be captivated by the compelling ensemble formed by the special AMG front wings, which are 20 mm wider than usual and bear “V8 BITURBO” lettering, the high-gloss black radiator grille with its three louvres, the darkened headlamps and the powerful AMG front apron with its integral LED daytime running lamps and matt chromed underguard. The spellbinding effect is compounded by the AMG side skirts painted in the vehicle colour and the special AMG rear apron with a chromed underguard. An impressively sound footing is provided by the 5-spoke light-alloy wheels painted in titanium grey with a high-sheen finish and equipped with 265/45 R 20 tyres, while the sports braking system with internally ventilated and perforated brake discs at the front and rear is ready to deliver suitably high-performance stopping power. The visual tour de force that is the ML 63 AMG is completed by the AMG sports



exhaust system whose two chromed twin tailpipes integrated into the bumper promise a no less thrilling acoustic experience.

Beneath this stunning exterior lies something even more impressive: the AMG V8 biturbo engine combined with the AMG SPEEDSHIFT PLUS 7-speed sports transmission is characterised by thrilling dynamics. On the one hand, this combination is able to provide a stirring driving experience with a rated output of 386 kW (525 hp) and a maximum torque of 700 Nm. On the other hand, it allows a reduction in fuel consumption of 26.5% compared with the predecessor model thanks to direct petrol injection with spray-guided combustion, twin turbochargers, alternator management and Controlled Efficiency mode with ECO start/stop function. The transmission offers three different driving modes: the first of these (“C”) is designed to enable driving with optimum fuel consumption; driving dynamics are enhanced noticeably through “Sport” (“S”) mode to “Manual” (“M”) mode. The sporty experience is also enhanced by the automatic double-declutching function as well as the characteristic sound.

The AMG speed-sensitive sports steering has a deliberately direct ratio and offers the optimum steering precision at high cornering speeds. The taut tuning of the springs and gas-pressure shock absorbers of the AMG sports suspension, which is based on the AIRMATIC suspension with the integral ACTIVE CURVE SYSTEM, ensures optimum

road feel and minimises body movements with the support of the two-stage ESP® dynamic handling control system and the AMG high-performance braking system.



Demonstratively dynamic: the expressive presence of the ML 63 AMG impresses from every angle.

## ML 63 AMG 4MATIC interior.

Powerful outside, stylish inside: high-quality materials and traditional craftsmanship form an outstanding partnership with resolutely sporty design inside the ML 63 AMG.



The interior of the ML 63 AMG features a thrilling mix of fine materials and dynamic design.

As soon as the doors are opened, attention focuses on the stainless-steel door sill panels with AMG lettering. AMG sports seats finished in single- and two-tone leather and featuring a special seat upholstery layout as well as AMG badges in the front and rear backrests create a welcoming ambience and are complemented by the ARTICO man-made leather trim on the upper section of the dashboard, the beltline, the armrests and the door centre panels. The AMG performance steering wheel trimmed in nappa leather with perforations in the grip area and silver-coloured aluminium shift paddles contributes to the dynamic ambience. This impression is reinforced by features such as AMG floor mats, the AMG sports pedals in stainless steel with rubber studs and the AMG instrument cluster with its colour display. The standard leather upholstery is available in three colours while two-tone leather upholstery and designo leather (without diamond-pattern quilting) are available as optional extras. The black roof liner, heated front seats and the sliding glass sunroof add the finishing touches to the exclusive ambience.

## ML 63 AMG 4MATIC Performance package and Performance Studio.

Express to impress – the AMG Performance Studio offers many attractive individualisation options which bring out the sporty presence of the ML 63 AMG even more emphatically.

The AMG Performance Studio offers a range of options to underline the dynamic side of the ML 63 AMG. The AMG Performance package boosts the output by 24 kW (33 hp) to 410 kW (557 hp) and increases the maximum torque by 60 Nm to 760 Nm. It also underlines the enhanced performance of the ML 63 AMG with visual cues such as red-painted AMG brake callipers, an AMG engine cover in carbon fibre and the AMG performance steering wheel.

An even more dynamic driving sensation is available with the AMG Driver's package which sees the electronically governed top speed raised to 280 km/h (and includes participation in professional driving training at the AMG Driving Academy). Also available as an option for the AMG model are high-shine AMG 5-twin-spoke light-alloy wheels in titanium grey with 295/35 R 21 tyres.

The AMG Performance Studio in Affalterbach can also meet other exclusive customer requests – from vehicle personalisation all the way to the production of one-off models.



AMG performance steering wheel.



AMG engine cover in carbon fibre.



Red-painted AMG callipers.



## Standard equipment | Selection.



Multifunction steering wheel in nappa leather.



Audio 20 CD (6-disc CD changer optional).



ISOFIX.



ATTENTION ASSIST.



Electric parking brake.



Door sill panels with Mercedes-Benz lettering.



THERMATIC.



Tail lights featuring LED fibre-optic technology.

## Optional extras | Selection.



Panoramic sliding sunroof.



Aluminium-look running boards.



Harman Kardon® Logic 7® surround sound system.



Night View Assist Plus.



Ambient lighting.



KEYLESS-GO.



Trailer coupling, partially power-operated.



Active Lane Keeping Assist.

## AMG Exterior Sports package.

The AMG Exterior Sports package completes the dynamic appearance of the M-Class with sporty and athletic styling elements.



The AMG Exterior Sports package gives the M-Class an even sportier presence.

The optional AMG Exterior Sports package adds to the dynamic presence of the M-Class. The AMG bodystyling impresses with front and rear aprons which differ from the standard version as well as vehicle-colour side skirts which have a particularly dynamic look. High-shine AMG 5-spoke light-alloy wheels with 255/50 R 19 tyres enhance the exterior design significantly while perforated front brake discs with a brake calliper aperture complete the impressive picture and make for a driving experience which is perfect in visual terms, too.







Rear bumper with special AMG rear apron.



AMG 5-spoke light-alloy wheels with 265/45 R 20 tyres, with a high-shine finish (optional).



AMG 5-twin-spoke light-alloy wheels with 265/40 R 21 tyres, with a high-shine finish (optional).

## Interior Sports package.

The Interior Sports package picks up the dynamic tone in the interior and creates a sportier vehicle character with high-class appeal.



The optional Interior Sports package offers an exclusive, sporty dimension for the M-Class. With their special design and reinforced lateral support, the fully power-adjustable sports seats for the driver and front passenger make a decidedly dynamic statement, as does the four-spoke sports steering wheel. The seats are upholstered in a combination of ARTICO man-made leather/DINAMICA microfibre in black or can be ordered optionally with combined nappa leather and leather upholstery in black, contrasting top-stitching being standard in either case. The door centre panels provide further attractive highlights and have a special design which differs from that of the standard version. Brushed stainless-steel sports pedals with rubber studs as well as black cord floor mats with leather edging and a Mercedes-Benz badge add the final dynamic touches to the interior.

The Interior Sports package enhances the passenger compartment with a range of attractive extras.







## designo.

Individuality at its most alluring: the optionally available designo range turns special individual requirements into reality. → [www.mercedes-benz.com/designo](http://www.mercedes-benz.com/designo)

The spectrum of exclusive designo appointments provides the option of making a special vehicle even more individual. Choosing designo leather for the seats and dashboard as well as the armrests on the doors and centre console along with leather door centre panels and upholstery in exclusive designo diamond-pattern quilting<sup>1</sup> creates an atmosphere of exceptional quality, whether in designo black,

porcelain or marron leather. As with all vehicles with a designo interior, the metal badge in the seat backrest stands for the meticulous selection of materials and attention to quality, painstaking craftsmanship and outstanding individuality. The appointments are completed by the black DINAMICA microfibre roof liner as well as the velour floor mats with designo black leather edging and

designo badges. What's more, the trim is optionally available in designo high-gloss black piano lacquer and a designo wood/leather steering wheel can also be ordered.



The designo interior: an ambience of outstanding driving pleasure and exceptional attention to detail.



The black headlining in DINAMICA microfibre.

<sup>1</sup> Diamond-pattern quilting not available for ML 63 AMG.

## Upholstery and trim.



For the black colour scheme it is possible to choose between seat covers in ARTICO man-made leather/fabric (standard) and optional upholstery in leather or (perforated) ARTICO man-made leather. The interior (seat covers, steering wheel, dashboard, door centre panels, carpet) is predominantly in black with contrast provided by the roof liner in alpaca grey. Trim elements in longitudinal-grain aluminium are standard while a wood trim and cup holder cover in various colours and varieties are available as an option. Where the optional Interior Sports package is ordered, the sports seats have black ARTICO man-made leather/DINAMICA microfibre upholstery or, as an option, black nappa leather/leather upholstery, contrasting decorative topstitching being common to both.

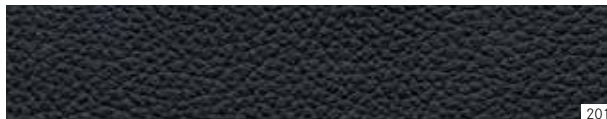

---

### black

- 001 ARTICO man-made leather/fabric
- 101 perforated ARTICO man-made leather<sup>1</sup>
- 201 leather<sup>2</sup>

---

### Trim

- 739 light longitudinal-grain aluminium
- 734 high-gloss brown eucalyptus wood<sup>3</sup>
- 731 high-gloss brown burr walnut wood<sup>3</sup>
- 729 high-gloss black poplar wood<sup>3</sup>
- H09 open-pore brown ash wood<sup>3</sup>
- W69 designo black piano lacquer<sup>3</sup>

---

<sup>1</sup> Standard for ML 500. <sup>2</sup> Standard for ML 63 AMG. <sup>3</sup> Optional extra.





For the optional almond beige colour scheme it is possible to choose between seat covers in (perforated) ARTICO man-made leather and leather upholstery. The interior (seat covers, door centre panels, roof liner, carpet) is predominantly in almond beige with contrast provided by the dashboard and steering wheel in mocha brown. Trim in light longitudinal-grain aluminium is standard while a wood trim and cup holder cover in various colours and varieties are available as an option.



105

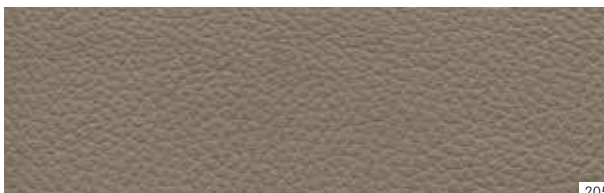

205



739



734



731



729



H09



W69

---

**almond beige**

---

- 105 perforated ARTICO man-made leather<sup>1</sup>
  - 205 leather<sup>2</sup>
- 

**Trim**

---

- 739 light longitudinal-grain aluminium
  - 734 high-gloss brown eucalyptus wood<sup>3</sup>
  - 731 high-gloss brown burr walnut wood<sup>3</sup>
  - 729 high-gloss black poplar wood<sup>3</sup>
  - H09 open-pore brown ash wood<sup>3</sup>
  - W69 designo black piano lacquer<sup>3</sup>
- 

<sup>1</sup> Standard for ML 500. <sup>2</sup> Standard for ML 63 AMG. <sup>3</sup> Optional extra.



For the optional alpaca grey colour scheme it is possible to choose between seat covers in (perforated) ARTICO man-made leather and leather upholstery. The interior (seat covers, door centre panels, roof liner) is predominantly in alpaca grey with contrast provided by the steering wheel, dashboard and the carpet in dark basalt grey. Trim elements in light longitudinal-grain aluminium are standard while a wood trim and cup holder cover in various colours and varieties are available as an option.



---

#### alpaca grey

108 perforated ARTICO man-made leather<sup>1</sup>

208 leather<sup>2</sup>

---

#### Trim

739 light longitudinal-grain aluminium

734 high-gloss brown eucalyptus wood<sup>3</sup>

731 high-gloss brown burr walnut wood<sup>3</sup>

729 high-gloss black poplar wood<sup>3</sup>

H09 open-pore brown ash wood<sup>3</sup>

W69 designo black piano lacquer<sup>3</sup>

---

<sup>1</sup> Standard for ML 500. <sup>2</sup> Standard for ML 63 AMG. <sup>3</sup> Optional extra.



The optional tobacco brown/marron/black colour scheme features two-tone seat upholstery in tobacco brown/marron as well as door centre panels and armrests in marron. The leather steering wheel, roof liner and dashboard provide a contrast in black. Here the leather steering wheel is in a contrasting black. Trim in light longitudinal-grain aluminium is standard while a wood trim and cup holder cover in various colours and varieties are available as an option.



---

**tobacco brown/marron/black**

254 leather<sup>1</sup>

---

**Trim**

- 739 light longitudinal-grain aluminium
  - 734 high-gloss brown eucalyptus wood<sup>2</sup>
  - 731 high-gloss brown burr walnut wood<sup>2</sup>
  - 729 high-gloss black poplar wood<sup>2</sup>
  - H09 open-pore brown ash wood<sup>2</sup>
  - W69 designo black piano lacquer<sup>2</sup>
- 

<sup>1</sup> Standard for ML 63 AMG. <sup>2</sup> Optional extra.





The optional almond beige/black colour scheme features seat upholstery plus door centre panels and armrests in light almond beige. The leather steering wheel, roof liner and dashboard are styled in black as a contrast to this. Trim in light longitudinal-grain aluminium is standard while a wood trim and cup holder cover in various colours and varieties are available as an option.



255



739

734

731

729

H09

W69

---

**almond beige/black**

---

255 leather<sup>1</sup>

---

**Trim**

---

739 light longitudinal-grain aluminium

734 high-gloss brown eucalyptus wood<sup>2</sup>731 high-gloss brown burr walnut wood<sup>2</sup>729 high-gloss black poplar wood<sup>2</sup>H09 open-pore brown ash wood<sup>2</sup>W69 designo black piano lacquer<sup>2</sup>

---

<sup>1</sup> Standard for ML 63 AMG. <sup>2</sup> Optional extra.



The optional alpaca grey/black colour scheme features seat upholstery plus door centre panels and armrests in light alpaca grey. The leather steering wheel, roof liner and dashboard are styled in black as a contrast to this. Trim in light longitudinal-grain aluminium is standard while a wood trim and cup holder cover in various colours and varieties are available as an option.



258



739



734



731



729



H09



W69

---

<b>alpaca grey/black</b>	
258	leather <sup>1</sup>
<b>Trim</b>	
739	light longitudinal-grain aluminium
734	high-gloss brown eucalyptus wood <sup>2</sup>
731	high-gloss brown burr walnut wood <sup>2</sup>
729	high-gloss black poplar wood <sup>2</sup>
H09	open-pore brown ash wood <sup>2</sup>
W69	designo black piano lacquer <sup>2</sup>

---

<sup>1</sup> Standard for ML 63 AMG. <sup>2</sup> Optional extra.

## Wheels.



10-spoke light-alloy wheels with 235/65 R 17 tyres (standard for ML 250 BlueTEC 4MATIC and ML 350 BlueTEC 4MATIC, Code 25R).



5-twin-spoke light-alloy wheels with 255/50 R 19 tyres (standard for ML 500 4MATIC, not for ML 63 AMG, Code R55).



7-spoke light-alloy wheels with 255/55 R 18 tyres (optional, not for ML 63 AMG and ML 500 4MATIC, Code 03R).



5-spoke light-alloy wheels with 255/50 R 19 tyres (optional, not for ML 63 AMG, Code R39).



10-spoke light-alloy wheels with 255/55 R 18 tyres (standard for ML 350 4MATIC, optional for diesel models, Code R41).



7-twin-spoke light-alloy wheels with 235/65 R 17 tyres (optional for ML 250 BlueTEC 4MATIC and ML 350 BlueTEC 4MATIC, Code R24).



7-spoke light-alloy wheels with 255/50 R 19 tyres (optional, not for ML 63 AMG, Code R53).



5-twin-spoke light-alloy wheels with 265/45 R 20 tyres (optional, not for ML 63 AMG, Code R33).





5-twin-spoke light-alloy wheels with 265/45 R 20 tyres, with high-sheen finish (optional, not for ML 63 AMG, Code 50R).



AMG 5-spoke light-alloy wheels with 255/50 R 19 tyres, with high-sheen finish (part of AMG Exterior Sports package, not for ML 63 AMG, Code 780).



AMG 5-spoke light-alloy wheels with 265/45 R 20 tyres, painted titanium grey with high-sheen finish (standard for ML 63 AMG, Code 778).



AMG 5-twin-spoke light-alloy wheels with 295/35 R 21 tyres, painted titanium grey with high-sheen finish (optional for ML 63 AMG, Code 798).



5-twin-spoke light-alloy wheels with 265/40 R 21 tyres, with high-sheen finish (optional, not for ML 63 AMG, Code 07R).



AMG 5-spoke light-alloy wheels with 265/45 R 20 tyres, with high-sheen finish (optional, not for ML 63 AMG, Code 758).



AMG 5-twin-spoke light-alloy wheels with 265/40 R 21 tyres, with high-sheen finish (optional, not for ML 63 AMG, Code 757).



AMG 5-twin-spoke light-alloy wheels with 295/35 R 21 tyres, painted matt black, with high-sheen rim flange (optional for ML 63 AMG, Code 685).

## Genuine accessories.

A Mercedes-Benz can be a travel companion, an office or a living space. The Mercedes-Benz range of genuine accessories is perfectly matched to the M-Class to enable it to perform this wide variety of roles even more effectively. → [www.mercedes-benz-accessories.com](http://www.mercedes-benz-accessories.com)

The iPad® Rear Integration Plus docking station allows the Apple iPad® to be integrated easily in the rear of the M-Class. All of the entertainment options stored on the iPad® remain available while the vehicle is on the move and the battery of the iPad® can also be charged at the same time. If the vehicle is also equipped with the InCar Hotspot, even an iPad® not equipped with UMTS functionality can be fully connected to the internet. Available for iPad®, iPad® 2, iPad® 3 and iPad® 4.



iPad® Rear Integration Plus makes all the functions of the iPad® available in the M-Class.

The high-sheen chrome-plated fin embellishers add a distinctive highlight to the bonnet and complete the chrome finish of the M-Class in style. Available as a six-part set, the sporty and elegant fin embellishers give the M-Class a unique look and are precision-engineered for fast and easy fitting.



Easily fitted, the fin embellishers create a striking effect.

Illuminated Mercedes star: in the M-Class the star on your radiator is like a shooting star: the central star in the radiator grille is illuminated when unlocking and locking the vehicle via remote control and also when opening the door or tailgate. The system only functions when the engine is switched off and does not function in conjunction with DISTRONIC PLUS.



Fibre-optic and LED technology makes your Mercedes star shine.

The generous amount of space it offers its occupants makes the M-Class the vehicle of choice for people who like to think big. Even more stowage space is available with the roof boxes, whose aerodynamic design optimised for Mercedes-Benz vehicles ensures that they fit in with the overall appearance of the M-Class harmoniously. And as well as looking good, they are made from extremely durable material. The lightweight aluminium carrier bars, which are precisely matched to the dimensions of the M-Class,

allow roof boxes to be attached quickly and easily. The roof boxes are also extremely convenient to load and unload as they can be opened from both sides. A range of different colours and sizes is available to meet customers' individual requirements.



Practical, aerodynamic, elegant: the roof box offers much more than just stowage space.



5-twin-spoke light-alloy wheels with 255/50 R 19 tyres.





## More than simply a star. A whole universe.

The range of **services from Mercedes-Benz**. Every Mercedes brings with it as a standard feature a reassuring feeling of safety on the road. But if you ever do need help, we're here for you around the clock. You can reach us from anywhere in Europe on the toll-free number 00800 1 777 7777<sup>1</sup> (or alternatively direct through Mercedes-Benz Contact<sup>2</sup>).

Ensuring that you can keep moving in the event of a technical breakdown, accident, vandalism or even misfuelling, the **Mercedes-Benz mobility package Mobilo<sup>3</sup>** is included as part of the standard specification. It covers the cost of local assistance, for example for towing your car away or for a replacement vehicle – and will do so in more than 40 countries across Europe for up to 30 years<sup>3</sup>. Furthermore, for the first four years following initial registration of the vehicle, Mobilo offers special mobility services in the case of workshop visits involving warranty or goodwill situations.

Avoid unexpected workshop costs<sup>4</sup>: a **Mercedes-Benz Service Contract** covers unforeseeable repairs, maintenance or wear parts, depending on the specific contract. Your local Mercedes-Benz dealer will be pleased to provide information about available Service Contracts and terms and conditions.

**Mercedes-Benz Financial Services.** Drive a Mercedes-Benz and remain flexible when it comes to payment: our attractive leasing and finance products make this possible – matched to your requirements and needs. We will also be happy to offer you a range of detailed insurance proposals. Just speak to your Mercedes-Benz dealer, who will be happy to provide information about our current range of financial services, terms and conditions.

<sup>1</sup> Alternatively: +49 69 95 30 72 77. Calls to a landline are chargeable. <sup>2</sup> Calls from a mobile phone to a landline are chargeable. <sup>3</sup> When it expires, (four years after initial registration) Mobilo can be extended to up to 30 years from one service to the next by your authorised Mercedes-Benz service partner. <sup>4</sup> Mercedes-Benz service contract terms and conditions apply.

### Enjoy the digital experience of Mercedes-Benz –

wherever you happen to be. Thanks to a range of offers optimised for smartphones and tablet computers, you can immerse yourself in the world of Mercedes-Benz even while on the move.

Insights into the full product range, a varied programme of entertainment and direct contact to a wide variety of services await you. Take an interactive tour with the **Interactive Owner's Manual**, for example, to get to know your dream car better. Experience the various functions in detail, take a close-up look at what's going on inside or explore the benefits of the particular model on your national Mercedes-Benz website.

With the **"Mercedes-Benz Guides"** app you can also explore the highlights of the various vehicles off-line. The app is available free of charge from the Apple® iTunes® Store (iOS) or the Google Play Store (Android).

Incidentally, our TV and magazine media are also available to watch and read digitally. Explore the whole brand world for yourself at [www.mercedes-benz.com](http://www.mercedes-benz.com). Just click to take a look.

The **fascination of Mercedes-Benz**. A car whose name brings a gleam to the eyes of people all over the world, one that has featured in many a movie and been sung about in international hits, is surely far more than just a car. How did it come to this?

Discover just what has been moving the world for more than 125 years and take a fascinating journey through time as well as through the history of the automobile, in the **Mercedes-Benz Museum**. More than 1500 exhibits over a display area of 16500 square metres demonstrate the unique heritage and innovative power of the inventor of the automobile, among them one-off models such as the oldest Mercedes still in existence, built in 1902, or the legendary "Gullwing" cars. Welcome to a place of innovation: [www.mercedes-benz-classic.com/museum](http://www.mercedes-benz-classic.com/museum)

What would the history of Mercedes-Benz be like without **motorsport**? What would motorsport be without Mercedes-Benz? The first vehicle ever to win an automobile race was powered by a Daimler engine. The first Mercedes was a racing car. The Silver Arrows – a true legend. Out of this glorious past has grown an exciting present: the MERCEDES AMG PETRONAS Formula 1 team and the DTM Mercedes AMG C-Coupés fight it out weekend after weekend for points and victory.



## Dimensions.

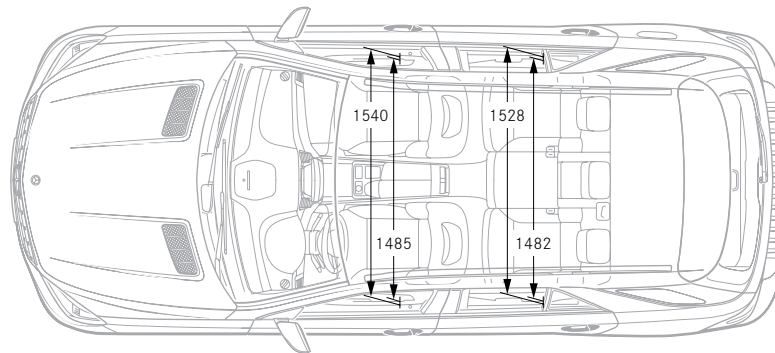
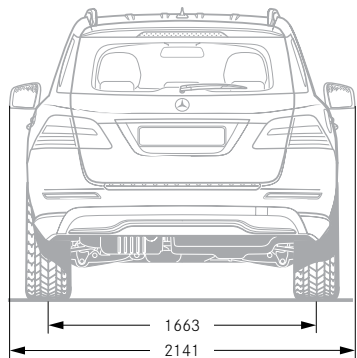
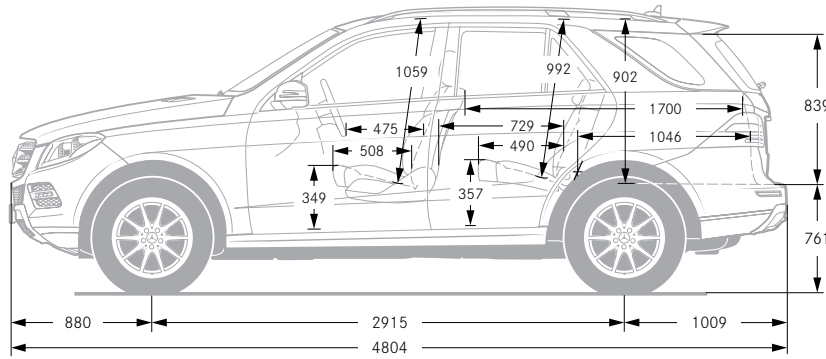
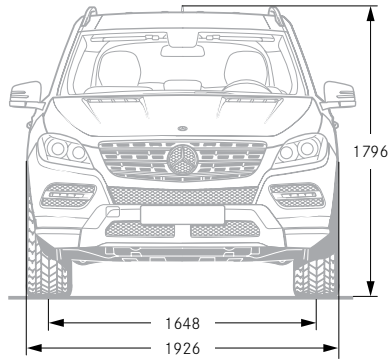

All dimensions in millimetres. The dimensions shown are mean values and apply to standard-specification, unladen vehicles.

## Paintwork.

The paint system developed by Mercedes-Benz includes one of the best clear coats on the automotive market and is a key factor behind the car's excellent value retention. Its secret is the exceptionally thick molecular structure, which makes the metallic or non-metallic clear coat more resistant and produces a longer lasting and visibly more intensive shine.

### Non-metallic paints

- 040 black
- 149 polar white

### Metallic paints<sup>1</sup>

- 151 cinnabar red
- 197 obsidian black
- 755 tenorite grey
- 775 iridium silver
- 792 palladium silver
- 796 citrine brown
- 890 cavansite blue
- 988 diamond silver

### designo paint<sup>1</sup>

- 799 designo diamond white bright

<sup>1</sup> Optional extra.



## Technical data.

	<b>Diesel engines</b>	
	<b>ML 250 BlueTEC 4MATIC</b>	<b>ML 350 BlueTEC 4MATIC</b>
No. of cylinders/arrangement	4/in-line	6/V
Transmission	7G-TRONIC PLUS	7G-TRONIC PLUS
Total displacement in cc	2143	2987
Rated output <sup>1</sup> in kW (hp) at rpm	150 (204)/3800	190 (258)/3600
Rated torque <sup>1</sup> in Nm at rpm	500/1600-1800	620/1600-2400
Acceleration from 0 to 100 km/h in s	9.0	7.4
Top speed, approx. in km/h	210	224
Tyre size	235/65 R 17	235/65 R 17
Fuel consumption <sup>2</sup> in l/100 km		
Urban	7.1-6.7	8.4-7.8
Extra-urban	5.7-5.3	6.8-6.3
Combined	6.2-5.8	7.4-6.8
CO <sub>2</sub> emissions <sup>2</sup> in g/km, combined	163-154	194-179
Efficiency class	A	B
Emission class <sup>3</sup>	Euro 6	Euro 6
Tank capacity in l/incl. approx. reserve	70/11.0	70/11.0
Load capacity in l		
Max. behind 2 <sup>nd</sup> seat row	690	690
Max. behind 1 <sup>st</sup> seat row	2010	2010
Turning circle diameter in m	11.80	11.80
Kerb weight <sup>4</sup> /perm. GVW in kg	2150/2950	2175/2950
Perm. towing capacity in kg, braked/unbraked	2950 <sup>5</sup> /750	3500/750

<sup>1</sup> Figures in accordance with Directive 80/1269/EEC in the currently applicable version. <sup>2</sup>The figures shown were obtained in accordance with the prescribed measuring process (Directive [EC] 715/2007) in the currently applicable version. The figures are not based on an individual model and do not constitute part of the product offer; they are provided solely for purposes of comparison between the different vehicle models. <sup>3</sup> Data applicable within the European Union only.

	<b>Petrol engines</b>		
	<b>ML 350 4MATIC</b>	<b>ML 500 4MATIC</b>	<b>ML 63 AMG 4MATIC</b>
No. of cylinders/arrangement	6/V	8/V	8/V
Transmission	7G-TRONIC PLUS	7G-TRONIC PLUS	AMG SPEEDSHIFT PLUS 7G-TRONIC
Total displacement in cc	3498	4663	5461
Rated output <sup>1</sup> in kW (hp) at rpm	225 (306)/6500	300 (408)/5000-5750	386 (525)/5250-5750 [410 (557)/5250-5750] <sup>7</sup>
Rated torque <sup>1</sup> in Nm at rpm	370/3500-5250	600/1600-4750	700/1750-5000 [760/2000-5000] <sup>7</sup>
Acceleration from 0 to 100 km/h in s	7.6	5.6	4.8 [4.7] <sup>7</sup>
Top speed, approx. in km/h	235	250 <sup>6</sup>	250 <sup>6,7</sup> [280] <sup>8</sup>
Tyre size	255/55 R 18	255/50 R 19	265/45 R 20
Fuel consumption <sup>2</sup> in l/100 km			
Urban	11.3-10.9	15.2-14.7	15.7
Extra-urban	7.4-7.1	9.5-8.9	9.6
Combined	8.8-8.5	11.5-11.0	11.8
CO <sub>2</sub> emissions <sup>2</sup> in g/km, combined	206-199	269-258	276
Efficiency class	C	F	F
Emission class <sup>3</sup>	Euro 5	Euro 6	Euro 5
Tank capacity in l/incl. approx. reserve	78/10.0	93/12.0	93/14.0
Load capacity in l			
Max. behind 2 <sup>nd</sup> seat row	690	690	690
Max. behind 1 <sup>st</sup> seat row	2010	2010	2010
Turning circle diameter in m	11.80	11.80	11.80
Kerb weight <sup>4</sup> /perm. GVW in kg	2130/2900	2235/2950	2345/3050
Perm. towing capacity in kg, braked/unbraked	3500/750	3500/750	3050/750

<sup>1</sup> Figures according to Directive 92/21/EC, version 95/48/EC (kerb weight with fuel tank 90% full, driver, 68 kg, and luggage, 7 kg) for standard-specification vehicles. Optional extras and accessories will generally increase this figure and reduce the payload capacity accordingly. <sup>5</sup> In conjunction with trailer coupling, Code 550, the braked towing capacity is 3500 kg. <sup>6</sup> Electronically governed. <sup>7</sup> In conjunction with AMG Performance package. <sup>8</sup> In conjunction with AMG Driver's package. Further technical data are available at [www.mercedes-benz.com](http://www.mercedes-benz.com)

Non-metallic paints

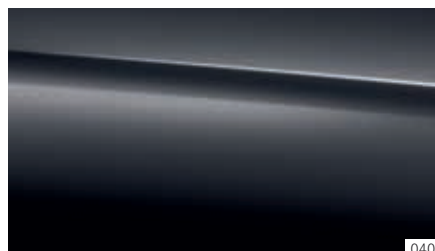

Metallic paints<sup>1</sup>

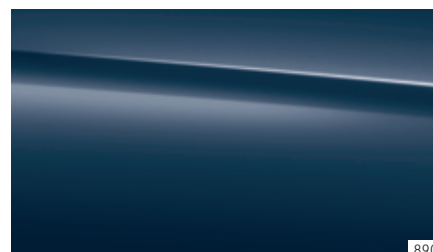
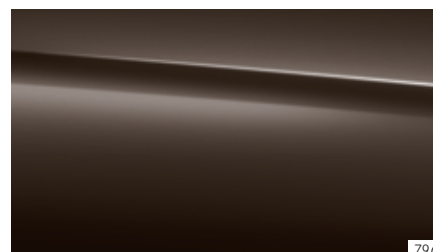
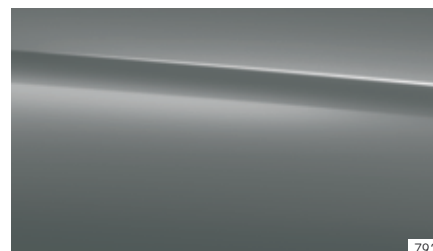
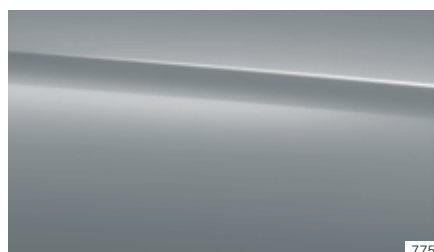
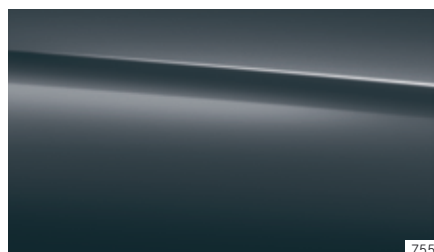
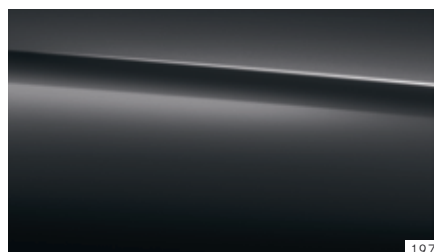
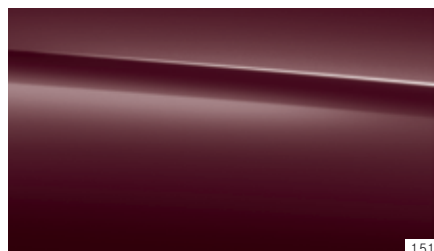

designo paint<sup>1</sup>





**Take-back of end-of-life vehicles.** At the end of its long life, you can return your M-Class to us for environment-friendly disposal in accordance with the European Union (EU) End-Of-Life Vehicle Directive. But that day lies a long way off.

A network of vehicle take-back depots and dismantlers has been established to make it as easy as possible for you to return your vehicle. You can leave it at any of these points free of charge and, by doing so, make an important contribution to completing the recycling process and conserving resources.

For further information about the recycling and disposal of end-of-life vehicles and take-back conditions, please visit your national Mercedes-Benz website.

**Please note:** changes may have been made to the product since this brochure went to press (27.01.2014). The manufacturer reserves the right during the delivery period to make changes to the design, form, colour or specification, provided these changes, while taking into account the interests of the vendor, can be deemed reasonable with respect to the purchaser. Where the vendor or the manufacturer uses symbols or numbers to describe an order or the subject of an order, no rights may be derived solely from these. The illustrations may include accessories and optional extras which do not form part of the standard specification. Actual colours may differ slightly from those shown owing to the limitations of the printing process. This brochure is distributed internationally. It provides a general indication of the range of models, features, optional extras, colours and/or services available in various countries. Some of the models, features, optional extras, colours and/or services shown may not be available in your country or may only be available in a different specification. Additionally some models, features, optional extras, colours and/or services may only be available in combination with others. For current and more specific information in relation to the range of models, features, optional extras, colours and/or services available in your country, and their pricing, you should contact your nearest authorised Mercedes-Benz Passenger Car Dealer.

**[www.mercedes-benz.com](http://www.mercedes-benz.com)**